



FSH HP 06V1FXC
FSH HP 09V1FXC
FSH HP 12V1FXC



DC Inverter Air to Water Heat Pump



User's manual

Before operating this product, please read the instructions carefully and keep this manual for future use.

Catalogue

1. Before use	4
1.1 Safety precautions	10
1.2 Working principle	12
1.3 Main components	13
1.4 Specifications	14
2. Installation	15
2.1 General application system introduction	15
2.2 Installation of the Monoblock unit	18
2.3 Accessories	20
2.4 Wiring	21
2.5 Water Pipe Connection	25
2.6 Test Run	26
3. Usage	27
3.1 Key icon and display of wire controller	27
3.2 Description and function of display icon of wire controller	29
3.3 Operating instructions for the wire controller	31
3.4 APP application	58
3.4 Other Functions of the Wire Controller	61
3.5 Other functions	68
4. Maintenance	70
4.1 Attention	70
4.2 Cleaning of water filter	70
4.3 Cleaning of plate heat exchanger	70
4.4 Condenser coil	71
4.5 Service of monoblock unit	72
4.6 Trouble-shooting	77
5. Attached drawing	79
5.1 Outlines and dimensions	79
5.2 Exploded view	81
5.3 Wiring diagram	83

1. Before use

Cautions:

1. Do not use means to accelerate the defrosting process or to clean, other than those recommended by the manufacturer.
2. The appliance shall be stored in a room without continuously operating ignition sources (for example: open flames, an operating gas appliance or an operating electric heater.).
3. Do not pierce or burn.
4. Be aware that refrigerants may not contain an odour.
5. Appliance shall be installed, operated and stored in a room with a floor area larger than X m² (refer to specifications sheet).
6. The installation of pipe-work shall be kept to a minimum X m² (refer to specifications sheet).
7. Spaces where refrigerant pipes shall be compliance with national gas regulations.
8. Servicing shall be performed only as recommended by the manufacturer.
9. The appliance shall be stored in a well-ventilated area where the room size corresponds to the room area as specified for operation.
10. All working procedure that affects safety means shall only be carried by competent persons.

General Notice:

1. Transport of equipment containing flammable refrigerants

Compliance with the transport regulations

2. Marking of equipment using signs

Compliance with local regulations

3. Disposal of equipment using flammable refrigerants

Compliance with national regulations

4. Storage of equipment/appliances

The storage of equipment should be in accordance with the manufacturer's instructions.

5. Storage of packed (unsold) equipment

Storage package protection should be constructed such that mechanical damage to the equipment inside the package will not cause a leak of the refrigerant charge.

The maximum number of pieces of equipment permitted to be stored together will be determined by local regulations.

6. Information on servicing

1) Checks to the area

Prior to beginning work on systems containing flammable refrigerants, safety checks are necessary to ensure that the risk of ignition is minimised. For repair to the refrigerating system, the following precautions shall be complied with prior to conducting work on the system.

2) Work procedure

Work shall be undertaken under a controlled procedure so as to minimise the risk of a flammable gas or vapour being present while the work is being performed.

1. Before use

3) General work area

All maintenance staff and others working in the local area shall be instructed on the nature of work being carried out. Work in confined spaces shall be avoided. The area around the workspace shall be sectioned off. Ensure that the conditions within the area have been made safe by control of flammable material.

4) Checking for presence of refrigerant

The area shall be checked with an appropriate refrigerant detector prior to and during work, to ensure the technician is aware of potentially flammable atmospheres. Ensure that the leak detection equipment being used is suitable for use with flammable refrigerants, i.e. non-sparking, adequately sealed or intrinsically safe.

5) Presence of fire extinguisher

If any hot work is to be conducted on the refrigeration equipment or any associated parts, appropriate fire extinguishing equipment shall be available to hand. Have a dry powder or CO₂ fire extinguisher adjacent to the charging area.

6) No ignition sources

No person carrying out work in relation to a refrigeration system which involves exposing any pipe work that contains or has contained flammable refrigerant shall use any sources of ignition in such a manner that it may lead to the risk of fire or explosion. All possible ignition sources, including cigarette smoking, should be kept sufficiently far away from the site of installation, repairing, removing and disposal, during which flammable refrigerant can possibly be released to the surrounding space. Prior to work taking place, the area around the equipment is to be surveyed to make sure that there are no flammable hazards or ignition risks. "No Smoking" signs shall be displayed.

7) Ventilated area

Ensure that the area is in the open or that it is adequately ventilated before breaking into the system or conducting any hot work. A degree of ventilation shall continue during the period that the work is carried out. The ventilation should safely disperse any released refrigerant and preferably expel it externally into the atmosphere.

8) Checks to the refrigeration equipment

Where electrical components are being changed, they shall be fit for the purpose and to the correct specification. At all times the manufacturer's maintenance and service guidelines shall be followed. If in doubt consult the manufacturer's technical department for assistance. The following checks shall be applied to installations using flammable refrigerants:

- The charge size is in accordance with the room size within which the refrigerant containing parts are installed;
- The ventilation machinery and outlets are operating adequately and are not obstructed;
- If an indirect refrigerating circuit is being used, the secondary circuit shall be checked for the presence of refrigerant;
- Marking to the equipment continues to be visible and legible. Markings and signs that are illegible shall be corrected;
- Refrigeration pipe or components are installed in a position where they are unlikely to be exposed to any substance which may corrode refrigerant containing components, unless the components are constructed of materials which are inherently resistant to being corroded or are suitably protected against being so corroded.

1. Before use

9) Checks to electrical devices

Repair and maintenance to electrical components shall include initial safety checks and component inspection procedures. If a fault exists that could compromise safety, then no electrical supply shall be connected to the circuit until it is satisfactorily dealt with. If the fault cannot be corrected immediately but it is necessary to continue operation, an adequate temporary solution shall be used. This shall be reported to the owner of the equipment so all parties are advised.

Initial safety checks shall include:

- .That capacitors are discharged: this shall be done in a safe manner to avoid possibility of sparking;
- .That there no live electrical components and wiring are exposed while charging, recovering or purging the system;
- .That there is continuity of earth bonding.

7.Repairs to sealed components

1)During repairs to sealed components, all electrical supplies shall be disconnected from the equipment being worked upon prior to any removal of sealed covers, etc. If it is absolutely necessary to have an electrical supply to equipment during servicing, then a permanently operating form of leak detection shall be located at the most critical point to warn of a potentially hazardous situation.

2) Particular attention shall be paid to the following to ensure that by working on electrical components, the casing is not altered in such a way that the level of protection is affected. This shall include damage to cables, excessive number of connections, terminals not made to original specification, damage to seals, incorrect fitting of glands, etc.

Ensure that apparatus is mounted securely.

Ensure that seals or sealing materials have not degraded such that they no longer serve the purpose of preventing the ingress of flammable atmospheres. Replacement parts shall be in accordance with the manufacturer's specifications.

NOTE: The use of silicon sealant may inhibit the effectiveness of some types of leak detection equipment. Intrinsically safe components do not have to be isolated prior to working on them.

8.Repair to intrinsically safe components

Do not apply any permanent inductive or capacitance loads to the circuit without ensuring that this will not exceed the permissible voltage and current permitted for the equipment in use.

Intrinsically safe components are the only types that can be worked on while live in the presence of a flammable atmosphere. The test apparatus shall be at the correct rating.

Replace components only with parts specified by the manufacturer. Other parts may result in the ignition of refrigerant in the atmosphere from a leak.

1. Before use

9.Cablling

Check that cabling will not be subject to wear, corrosion, excessive pressure, vibration, sharp edges or any other adverse environmental effects. The check shall also take into account the effects of aging or continual vibration from sources such as compressors or fans.

10.Detection of flammable refrigerants

Under no circumstances shall potential sources of ignition be used in the searching for or detection of refrigerant leaks. A halide torch (or any other detector using a naked flame) shall not be used.

11.Leak detection methods

The following leak detection methods are deemed acceptable for systems containing flammable refrigerants.

Electronic leak detectors shall be used to detect flammable refrigerants, but the sensitivity may not be adequate, or may need re-calibration. (Detection equipment shall be calibrated in a refrigerant-free area.) Ensure that the detector is not a potential source of ignition and is suitable for the refrigerant used. Leak detection equipment shall be set at a percentage of the LFL of the refrigerant and shall be calibrated to the refrigerant employed and the appropriate percentage of gas (25% maximum) is confirmed.

Leak detection fluids are suitable for use with most refrigerants but the use of detergents containing chlorine shall be avoided as the chlorine may react with the refrigerant and corrode the copper pipe-work.

If a leak is suspected, all naked flames shall be removed/ extinguished.

If a leakage of refrigerant is found which requires brazing, all of the refrigerant shall be recovered from the system, or isolated (by means of shut off valves) in a part of the system remote from the leak. Oxygen free nitrogen (OFN) shall then be purged through the system both before and during the brazing process.

12.Removal and evacuation

When breaking into the refrigerant circuit to make repairs – or for any other purpose –conventional procedures shall be used. However, it is important that best practice is followed since flammability is a consideration. The following procedure shall be adhered to:

- Remove refrigerant;
- Purge the circuit with inert gas;
- Evacuate;
- Purge again with inert gas;
- Open the circuit by cutting or brazing.

The refrigerant charge shall be recovered into the correct recovery cylinders. The system shall be “flushed” with OFN to render the unit safe. This process may need to be repeated several times. Compressed air or oxygen shall not be used for this task.

Flushing shall be achieved by breaking the vacuum in the system with OFN and continuing to fill until the working pressure is achieved, then venting to atmosphere, and finally pulling down to a vacuum. This process shall be repeated until no refrigerant is within the system. When the final OFN charge is used, the system shall be vented down to atmospheric pressure to enable work to take place. This operation is absolutely vital if brazing operations on the pipe-work are to take place. Ensure that the outlet for the vacuum pump is not close to any ignition sources and there is ventilation available.

1. Before use

13. Charging procedures

In addition to conventional charging procedures, the following requirements shall be followed.

- Ensure that contamination of different refrigerants does not occur when using charging equipment. Hoses or lines shall be as short as possible to minimise the amount of refrigerant contained in them.
- Cylinders shall be kept upright.
- Ensure that the refrigeration system is earthed prior to charging the system with refrigerant.
- Label the system when charging is complete (if not already).
- Extreme care shall be taken not to overfill the refrigeration system.

Prior to recharging the system it shall be pressure tested with OFN. The system shall be leak tested on completion of charging but prior to commissioning. A follow up leak test shall be carried out prior to leaving the site.

14. Decommissioning

Before carrying out this procedure, it is essential that the technician is completely familiar with the equipment and all its detail. It is recommended good practice that all refrigerants are recovered safely. Prior to the task being carried out, an oil and refrigerant sample shall be taken in case analysis is required prior to re-use of reclaimed refrigerant. It is essential that electrical power is available before the task is commenced.

- a) Become familiar with the equipment and its operation.
- b) Isolate system electrically.
- c) Before attempting the procedure ensure that:
 - .Mechanical handling equipment is available, if required, for handling refrigerant cylinders;
 - .All personal protective equipment is available and being used correctly;
 - .The recovery process is supervised at all times by a competent person;
 - .Recovery equipment and cylinders conform to the appropriate standards.
- d) Pump down refrigerant system, if possible.
- e) If a vacuum is not possible, make a manifold so that refrigerant can be removed from various parts of the system.
- f) Make sure that cylinder is situated on the scales before recovery takes place.
- g) Start the recovery machine and operate in accordance with manufacturer's instructions.
- h) Do not overfill cylinders. (No more than 80% volume liquid charge).
- I) Do not exceed the maximum working pressure of the cylinder, even temporarily.
- j) When the cylinders have been filled correctly and the process completed, make sure that the cylinders and the equipment are removed from site promptly and all isolation valves on the equipment are closed off.
- k) Recovered refrigerant shall not be charged into another refrigeration system unless it has been cleaned and checked.

15. Labelling

Equipment shall be labelled stating that it has been de-commissioned and emptied of refrigerant. The label shall be dated and signed. Ensure that there are labels on the equipment stating the equipment contains flammable refrigerant.

16. Recovery

When removing refrigerant from a system, either for servicing or decommissioning, it is recommended good practice that all refrigerants are removed safely.

When transferring refrigerant into cylinders, ensure that only appropriate refrigerant recovery cylinders are employed. Ensure that the correct number of cylinders for holding

1. Before use

the total system charge is available. All cylinders to be used are designated for the recovered refrigerant and labelled for that refrigerant (i.e. special cylinders for the recovery of refrigerant). Cylinders shall be complete with pressure relief valve and associated shut-off valves in good working order. Empty recovery cylinders are evacuated and, if possible, cooled before recovery occurs. The recovery equipment shall be in good working order with a set of instructions concerning the equipment that is at hand and shall be suitable for the recovery of flammable refrigerants. In addition, a set of calibrated weighing scales shall be available and in good working order. Hoses shall be complete with leak-free disconnect couplings and in good condition. Before using the recovery machine, check that it is in satisfactory working order, has been properly maintained and that any associated electrical components are sealed to prevent ignition in the event of a refrigerant release.

Consult manufacturer if in doubt.

The recovered refrigerant shall be returned to the refrigerant supplier in the correct recovery cylinder, and the relevant Waste Transfer Note arranged. Do not mix refrigerants in recovery units and especially not in cylinders.

If compressors or compressor oils are to be removed, ensure that they have been evacuated to an acceptable level to make certain that flammable refrigerant does not remain within the lubricant. The evacuation process shall be carried out prior to returning the compressor to the suppliers. Only electric heating to the compressor body shall be employed to accelerate this process. When oil is drained from a system, it shall be carried out safely.

1. Before use

1.1 Safety precautions

The following symbols are very important. Please be sure to understand their meaning, which concerns the product and your personal safety.



Warning



Caution



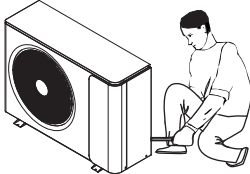

Prohibition

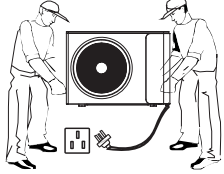

The installation, dismantlement and maintenance of the unit must be performed by qualified personnel. It is forbidden to do any changes to the structure of the unit. Otherwise injury of person or unit damage might happen.



To avoid electrical shock, make sure to disconnect the power supply 1 minute or more before servicing the electrical parts. Even after 1 minute, always measure the voltage at the terminals of main circuit capacitors or electrical parts and, before touching, make sure that those voltages are lower than the safety voltage.



Be sure to read this manual before use.

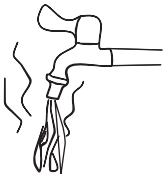

For sanitary hot water, please always add a mixture valve before water tap and set it to proper temperature.

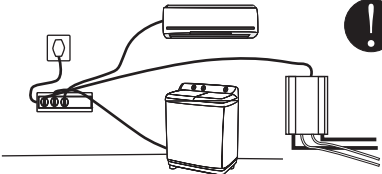

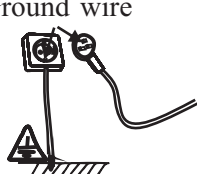

Use a dedicated socket for this unit, otherwise malfunction may occur.



Ground wire



The power supply to the unit must be grounded.



This appliance can be used by children aged from 8 years and above and persons with reduced physical, sensory or mental capabilities or lack of experience and knowledge if they have been given supervision or instruction concerning use of the appliance in a safe way and understand the hazards involved. Children shall not play with the appliance. Cleaning and user maintenance shall not be made by children without supervision.

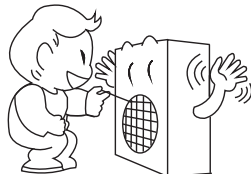

Do not touch the air outlet grill when fan motor is running.

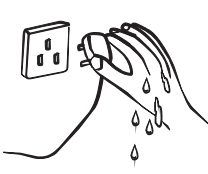

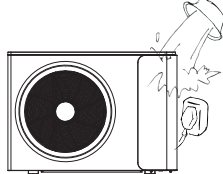

Do not touch the power plug with wet hands. Never pull out the plug by pulling the power cable.

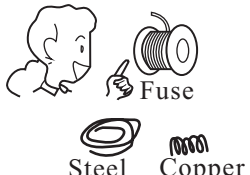
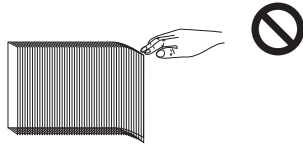

Water or any kind of liquid is strictly forbidden to be poured into the product, or may cause electric creepage or breakdown of the product.

1. Before use

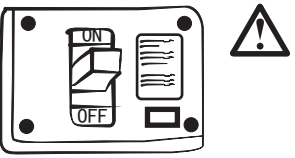
		
<p>When the power cord gets loose or damaged, always get a qualified person to fix it.</p>	<p>Please select the correct fuse or breaker as per recommended. Steel wire or copper wire cannot be taken as substitute for fuse or breaker. Otherwise, damages maybe caused.</p>	<p>Be aware fingers might be hurt by the fin of the coil.</p>

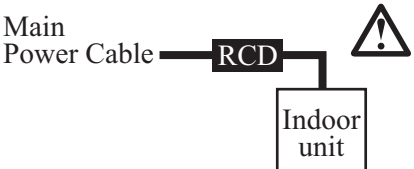
		
<p>It is mandatory to use a suitable circuit breaker for the heat pump and make sure the power supply to the unit corresponds to the specifications. Otherwise the unit might be damaged.</p>	<p>Disposal of Scrap Batteries(if there is). Please discard the batteries as sorted municipal waste at the accessible collection point.</p>	<p>Installation of a residual current device (RCD) having a rated residual operating current not exceeding 30 mA is advisable.</p>

 **System water filling**

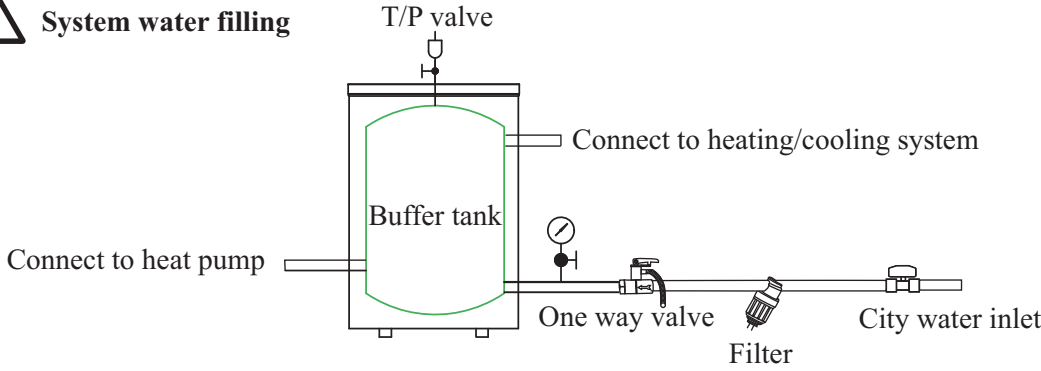

1. It's suggested to use pure water for filling the system.
 2. If use city water for filling, please soften the water and add a filter.
 Note: After filling, the system of water system should be 0.15~0.6MPa.

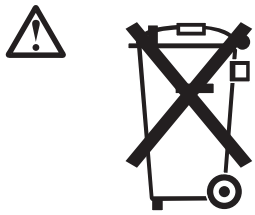
	<p>This marking indicates that this product should not be disposed with other household wastes throughout the EU. To prevent possible harm to the environment or human health from uncontrolled waste disposal, recycle it responsibly to promote the sustainable reuse of material resources. To return your used device, please use the return and collection systems or contact the retailer where the product was purchased. They can take this product for environmental safe recycling.</p>
---	---

1. Before use

1.2 Working principle

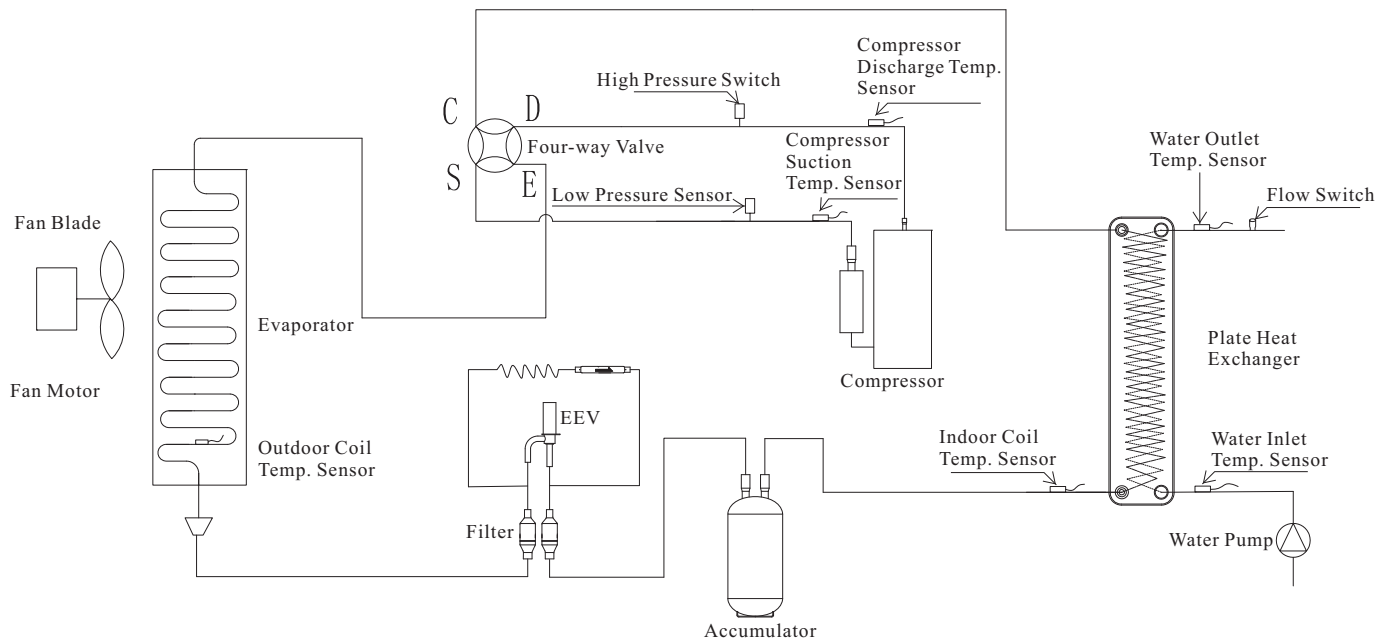

1. Before use

1.3 Main components

FSH HP 06V1FXC
FSH HP 09V1FXC
FSH HP 12V1FXC

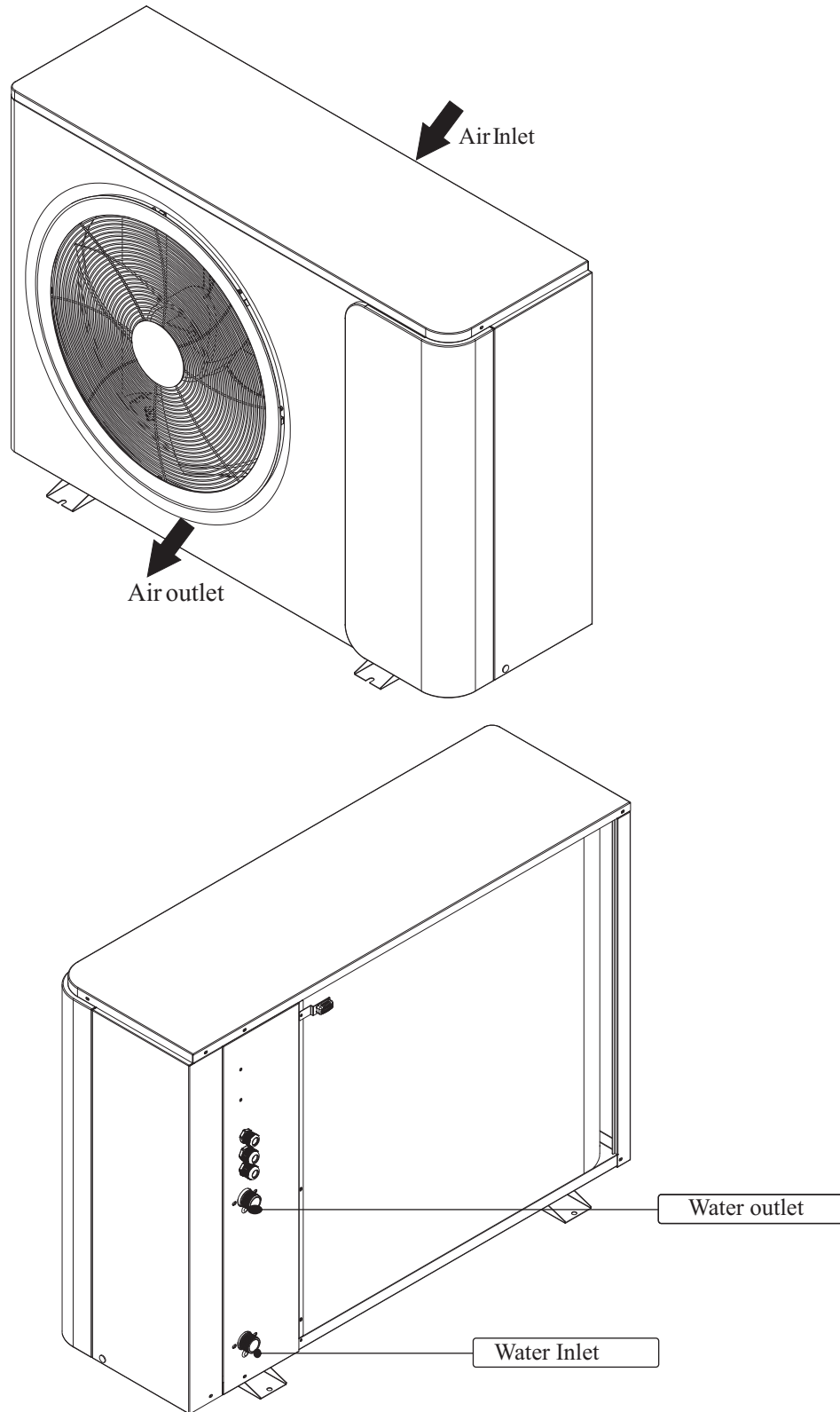

1. Before use

1.4 Specifications

Model			FSH HP 06V1FXC	FSH HP 09V1FXC	FSH HP 12V1FXC
Power Supply / Refrigerant		V/Hz/Ph	220~240/50/1-R32		
Workable Ambient Temperature Range		°C	-25~43		
Min. System Water Temperature (Heating / Cooling)		°C	20/7		
Fuse of circuit (Board Outdoor PCB)			T30AL/250V		
Min. Floor Area for installation, operation and storage		m ²	7	17	28
Min. Area of Pipe-work		m ²	7	17	28
Max. Operation High Pressure		MPa	4.2		
Max. Operation Low Pressure		MPa	1.4		
Refrigerant	Type / Amount	-/kg	R32/0.75kg	R32/1.15kg	R32/1.3kg
Compressor	Type - Quantity/System		Twin Rotary -1	Twin Rotary -1	Twin Rotary -1
Fan	Quantity		1	1	1
	Airflow	m ³ /h	2500	3150	3150
	Rated power	W	34	45	45
Noise Level	Outdoor (A7W35)	dB(A)	50	56	56
Water Side Heat Exchanger	Type		Plate Heat Exchanger	Plate Heat Exchanger	Plate Heat Exchanger
	Water Pressure Drop	kPa	26	26	26
	Piping Connection	Inch	G1"	G1"	G1"
Allowable Water Flow	Min./Rated./Max.	L/S	0.21/0.29/0.35	0.26/0.43/0.52	0.34/0.57/0.68
Net Dimension (L*D*H)	Outdoor Unit	mm	1015x380x700	1175x380x845	1175x380x845
Net Weight	Outdoor Unit	Kg	70	79	82

Note: (1) The specifications are subject to change without prior notice. For actual specifications of unit, please refer to the stickers on the unit.

2. Installation

2.1 General application system introduction

HEAT PUMP WITH DIRECT CONNECTION

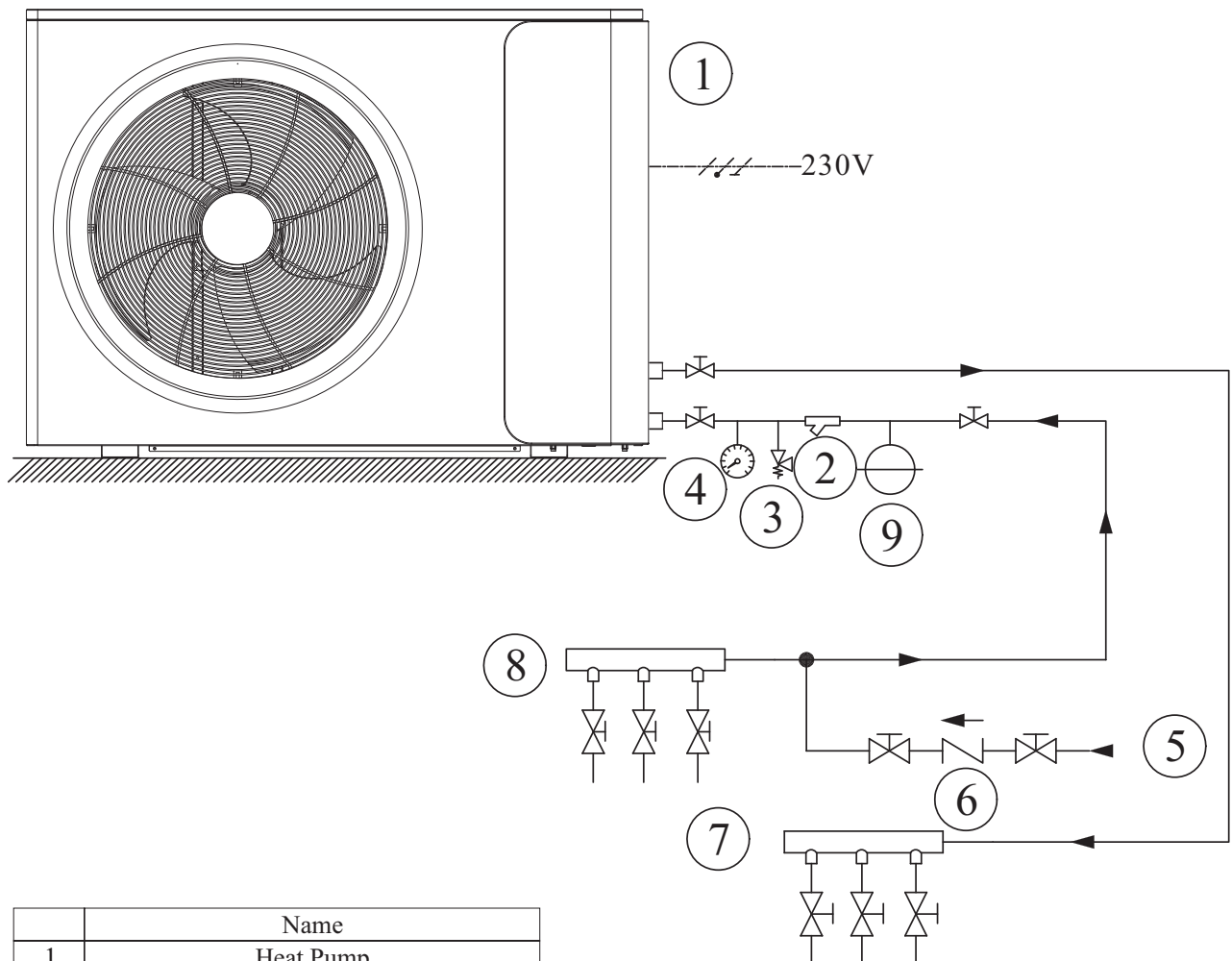

	Name
1	Heat Pump
2	Filter
3	Safe Valve
4	Water pressure gauge
5	Water inlet
6	One way valve
7	Supply to manifold heating/cooling
8	Return from manifold heating/cooling
9	Expansion vessel

NOTE: It is not necessary to change any settings for operation with this scheme.

2. Installation

HEAT PUMP WITH SERIES BUFFER

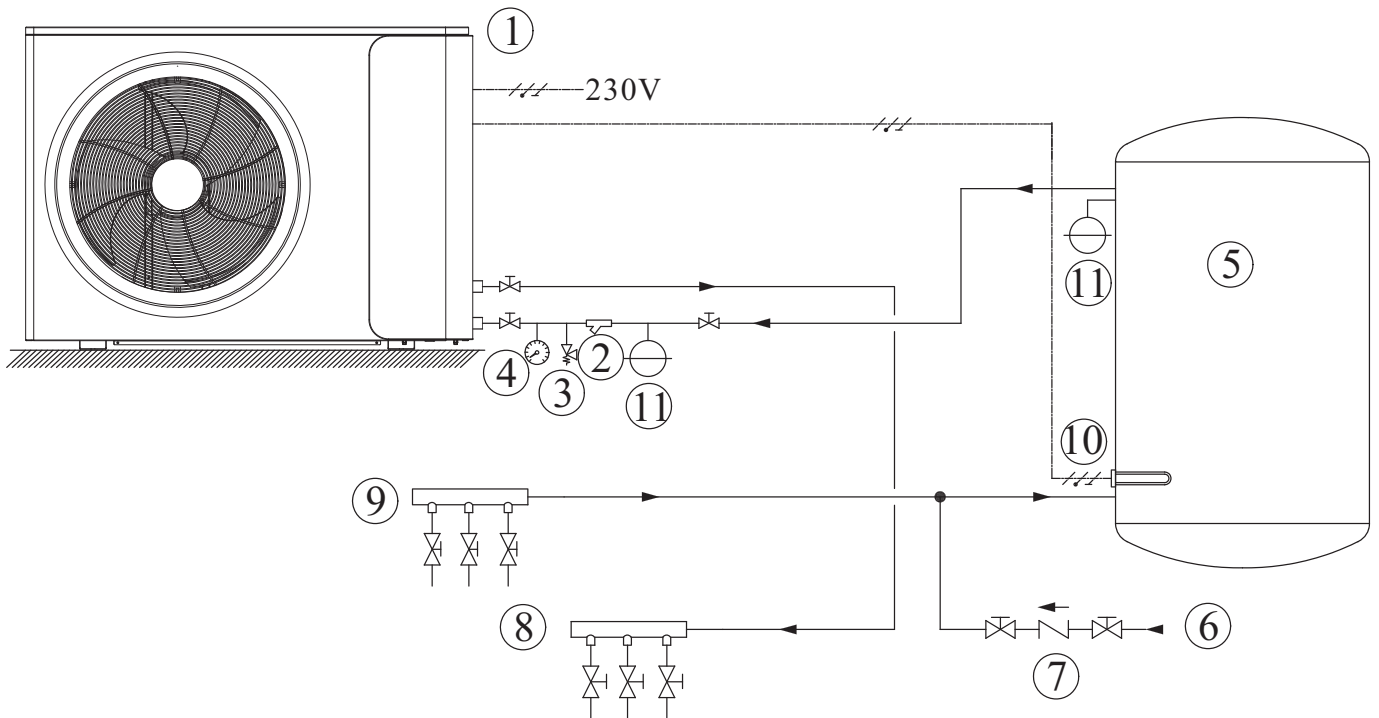

	Name
1	Heat Pump
2	Filter
3	Safe valve
4	Water pressure gauge
5	Buffer tank
6	Water inlet
7	One way valve
8	Supply to manifold heating/cooling
9	Return from manifold heating/cooling
10	Electrical heater (optional)
11	Expansion vessel

NOTE: It is not necessary to change any settings for operation with this scheme.
Connect the electrical heater (10 – optional) with a correct relay .

2. Installation

HEAT PUMP WITH PARALLEL BUFFER

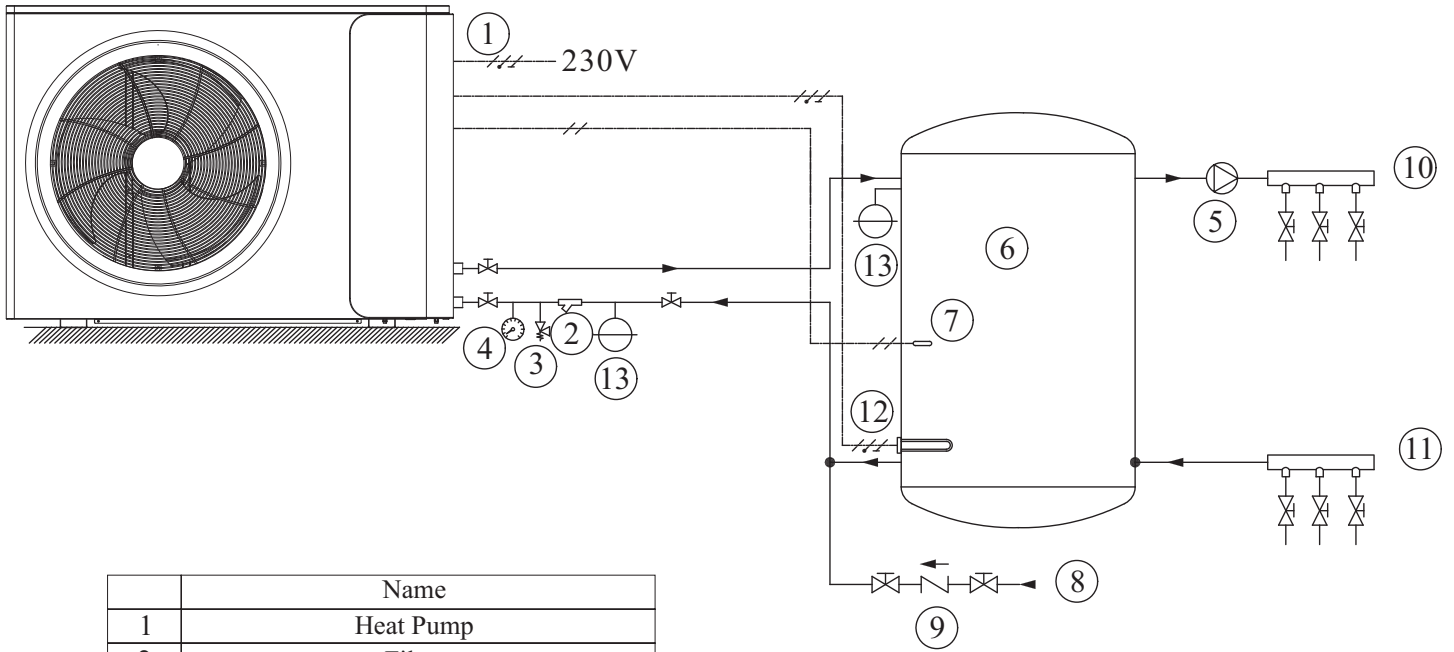

	Name
1	Heat Pump
2	Filter
3	Safe Valve
4	Water pressure gauge
5	Circulation pump
6	Buffer tank
7	“Tw” Tank temperature sensor
8	Water inlet
9	One way valve
10	Supply to manifold heating/cooling
11	Return from manifold heating/cooling
12	Electrical heater (optional)
13	Expansion vessel

NOTE:

The probes “Tw” (7) are assembled inside the appliance on the supply tube.
For put them on the tank it’s necessary remove the top and front cover of appliance, remove the probes and with the extension cable put them on the tank.

Connect the electrical heater (12 – optional) with a correct relay .

2. Installation

2.2 Installation of the monoblock unit

2.2.1 Installation notes

- 1) The monoblock unit can be located in a open space, corridor, balcony, and roof.
- 2) The monoblock unit shall be placed in dry and well-ventilated environment; If the monoblock unit is installed in humid environment, electronic components may get corroded, or short-circuited because of heavy humidity.
- 3) Monoblock unit mustn't be installed in an environment where volatile, corrosive or flammable liquid or gas exists.
- 4) Please don't install monoblock unit close to bedroom or living room, because there is some noise when it's running.
- 5) When installing the unit in harsh climatic conditions, sub-zero temperatures, snow, humidity..., please raise the unit above the ground by about 50cm.
It's recommended to install an awning above the monoblock unit, to protect the snow from clogging in the air inlet and outlet and ensure the normal running.
- 6) Please ensure there is drainage system around the location, to drain the condensate water under defrosting mode.
- 7) When installing the unit, tilt it by 1cm/m for rain water evacuation.
- 8) Install monoblock unit far away from the exhaust port of kitchen, to avoid oil smoke entering into monoblock unit and adhering to heat exchanger. It's hard to clean up.
- 9) Please don't install the indoor control unit and monoblock unit in damp locations, otherwise it may cause short-circuit or corrosion of some components. The unit should be free from corrosive and moisture surrounding. Otherwise the lifetime of the unit might be shortened.
- 10) Please ensure enough space around the monoblock unit, for better ventilation and maintenance.
Please refer to the illustration below.

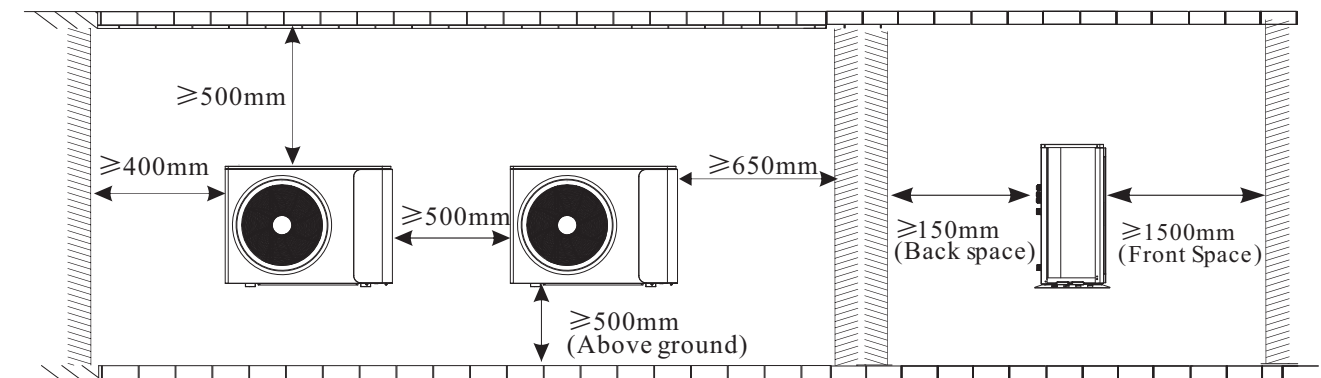

2. Installation

2.2.2 Installation

User can either use the dedicated mounting bracket from the supplier, or prepare a suitable bracket for the unit installation. Make sure the installation meets following requirements:

- 1) The unit must be installed on flat concrete blocks, or a dedicated mounting bracket. The bracket should be able to support at least 5 times of unit's weight.
- 2) All nuts must be tightened after the bracket is fixed; otherwise, it may cause damage to the equipment.
- 3) User should double check and make sure the installation of unit is firm enough.
- 4) The bracket can be of stainless steel, galvanized steel, aluminum and other materials as required by the user.
- 5) Besides the mounting bracket, the user can also install the monoblock unit on two concrete blocks, or a raised concrete platform. Please make sure that the unit is securely fastened after installation.
- 6) Please see the dimensions of monoblock unit when choose a suitable wall bracket.

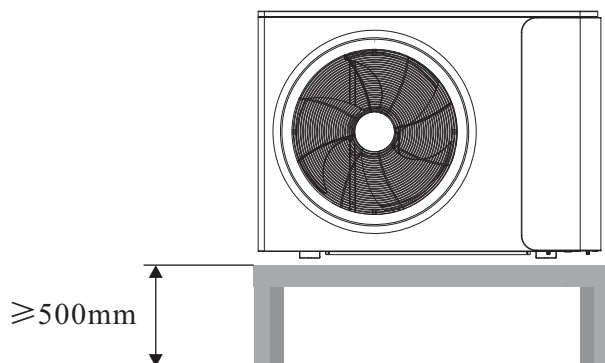

- ◆ Hole for piping kits should lean to outside a little bit (≥ 8 degrees), to keep rain water or condensate water from flowing back indoors.

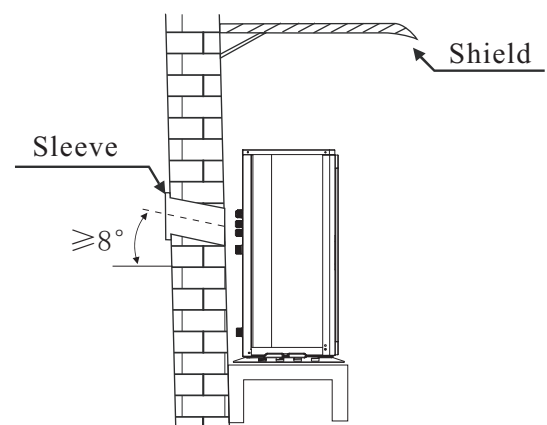



2. Installation

2.3 Accessories

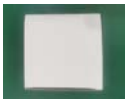

Accessories below are delivered together with the product .
Please check in time. If there is any shortage or damage, please contact local distributor.

Name	Quantity	Picture
Manual	1	
Operation panel	1	
Operation panel communication cable	1	
Green straight rubber granules	2	
Screws	2+2	

2. Installation

2.4 Wiring

- ◆ It is recommended to use a suitable circuit breaker for the heat pump;
- ◆ The power supply to the heat pump unit must be grounded.
- ◆ The wiring should be done by professional person.
- ◆ The wiring should be comply with the local industry regulation.
- ◆ The wiring should be done after the unit is powered off.
- ◆ Cable should be fixed tightly, to ensure it won't get loose.
- ◆ Don't connect several parts of cables together to use.
- ◆ Make sure the power supply in the local coincide with the power supply marked in rating label.
- ◆ Make sure power supply, cable and socket can meet the requirement of the input power of the unit.



2. Installation

2.4.1 Connect power cable

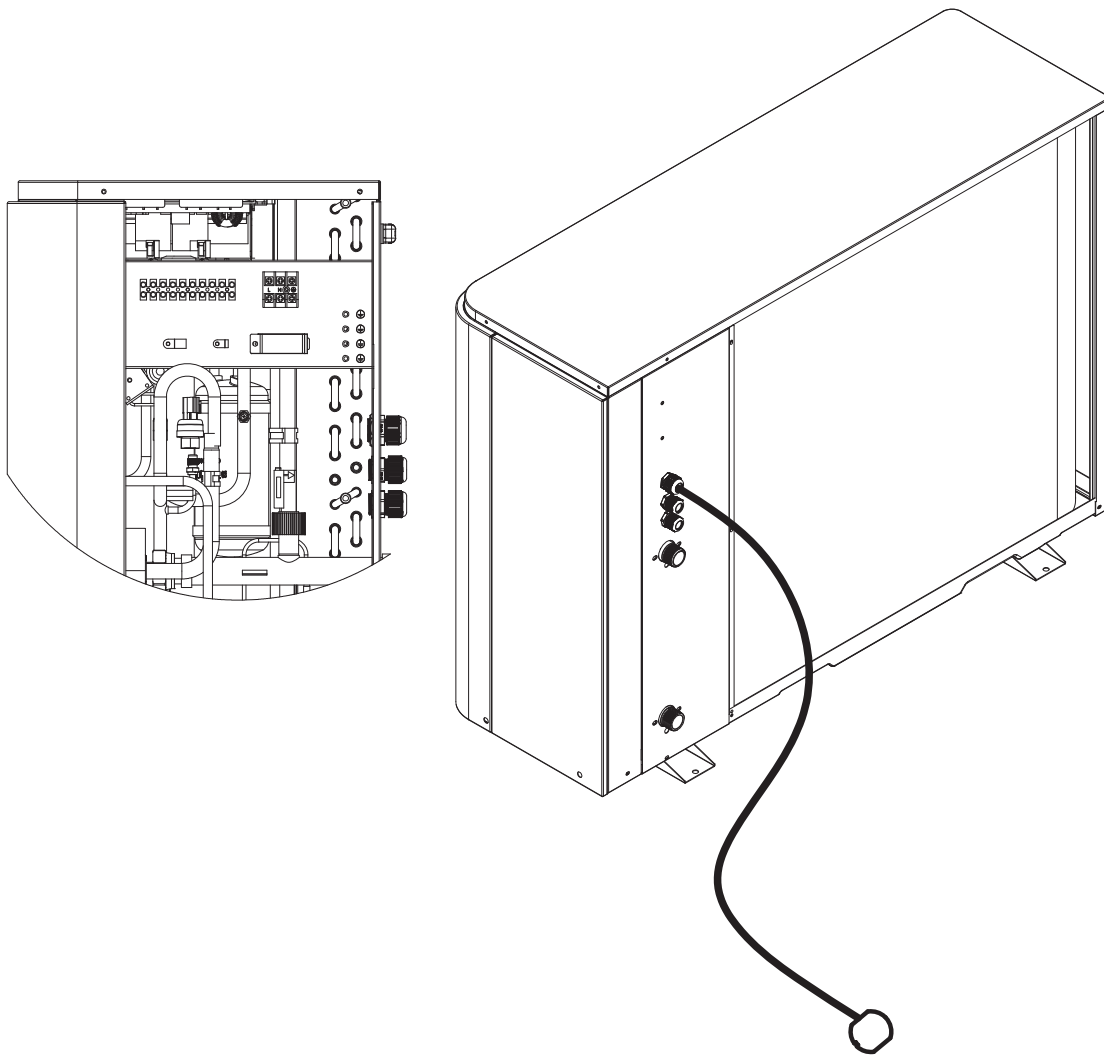

- A. Dismantle the service panel.
- B. Insert one end of this cable through the cable gland.
- C. Connect this cable to L, N, PE on terminal block.

2. Installation

2.4.2 Connect operation panel

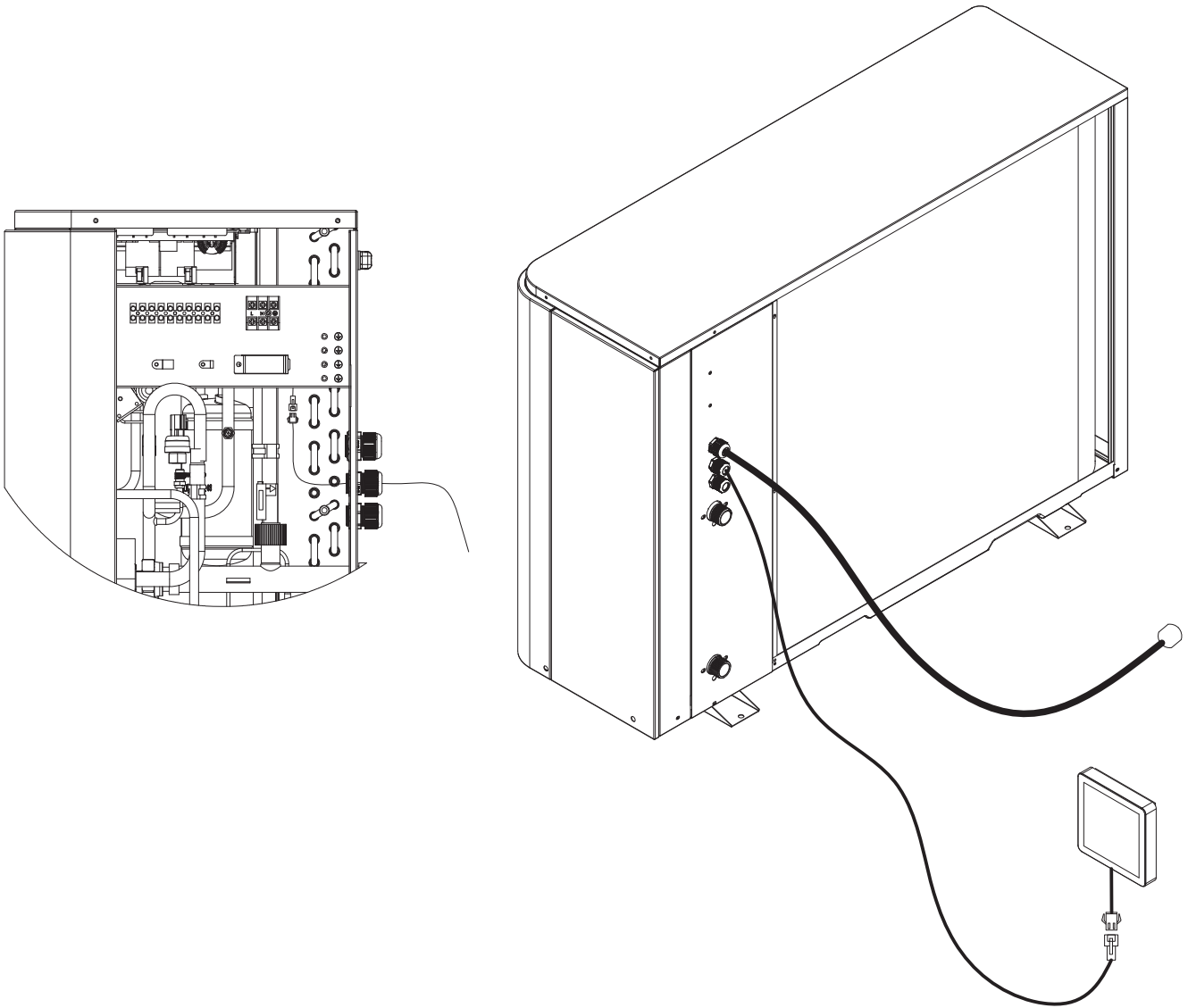

- A. Take operation panel and its extension cable out from accessories bag.
- B. Insert one end of the extension cable through cable gland, and have it connected to the terminal block on the unit, and the other end connect to operation panel.
- C. Fix the operation panel to the wall. NOTE: Operation panel is not water proof type. Add a water proof box if operation panel need to be placed outside the house.
- D. Install the service panel back.

2. Installation

2.4.3 Installation of the operation panel (wire controller)

1 Installation location and requirements of the operation panel (wire controller)

- 1) Do not install the operation panel in damp places or places with direct sunlight;
- 2) Do not install the operation panel near high temperature objects or places with possible splash water;
- 3) Please cut off the power supply of the heat pump before installation, and the whole installation process should proceed without electricity;
- 4) In order to avoid abnormal operation of due to factors like electromagnetic interference, make sure that the communication cable of the operation panel is connected correctly, otherwise it will cause communication failure.

2.4.4 Installation and removal of the operation panel

1) Install the operation panel directly on the wall

- a. Drill two $\phi 6\text{mm}$ holed on the wall. The two holes are required to be on a horizontal line, and the distance between the centers of the two holes is 60mm;
- b. The accessories of the unit are equipped with two green $\phi 6 \times 30\text{mm}$ straight cylinder rubber granules. Knock these two rubber granules into the holes;
- c. Use a flat-blade screwdriver to pry off the rear cover of the operation panel, then stick the rear cover to the wall, and use the $\text{ST}4.2 \times 30$ screws to fix the rear cover on the holes on the wall;
- d. Connect the communication cable of the operation panel, and press the operation panel onto the rear cover to complete the installation.

2) Fix the operation panel on the socket

- a. Use a flat-blade screwdriver to pry off the rear cover of the operation panel, then stick the rear cover to the socket, and use $\text{M}4 \times 16\text{mm}$ screws to fix the rear cover on the socket;
- b. Connect the communication cable of the operation panel, and press the operation panel onto the rear cover to complete the installation.

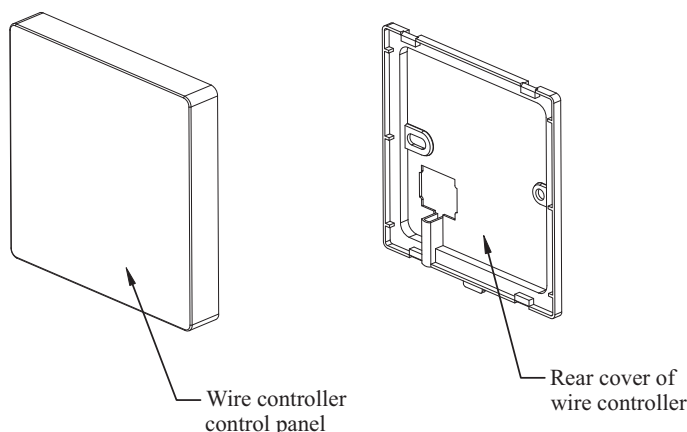

2. Installation

2.5 Water pipe connection

After installing the unit, please connect the water inlet and outlet pipe according to the local regulations. Please carefully select and operate the water pipe.

After connection, the water piping should be pressure tested, cleaned before use.

1) Filter

A mesh filter must be installed in front of the water inlet of the unit and water tank, to keep the water quality and collect impurity contained in the water. Take care to keep the water filter mesh towards the bottom. Check valve is recommended to be installed at both sides of the filter, so as to clean or change the filter in a easier way.

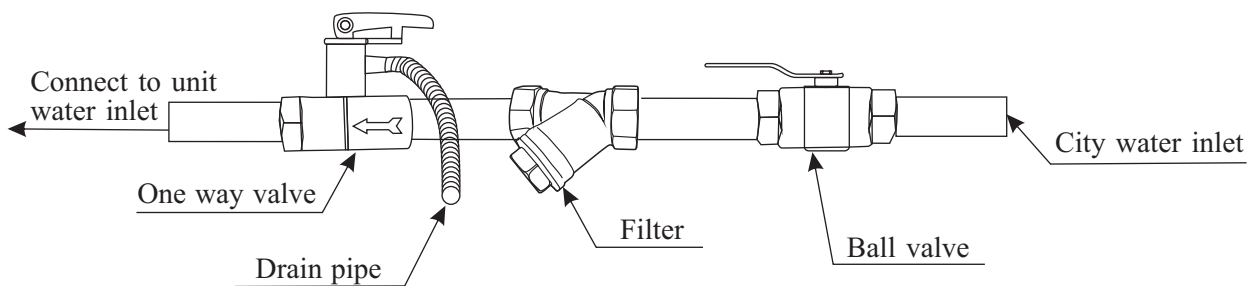

2) Insulation

All pipes running hot water should be well insulated. The insulation must be tied up tightly without gap (But please don't wrap up the check valve for future maintenance).



Please ensure enough water pressure to send the water to the required height.
If the water pressure is not enough to maintain proper water flow rate for the system, please add a water pump to increase the pumping head.

3) Requirements of water quality

- A. Chloridion element in the water should be less than 300ppm(temperature is less than 60°C).
- B. PH value of water should be from 6 to 8.
- C. The water with ammonia can't be used for the unit.

If the water quality is bad, or water flow too little, scale formation or clogging may happen after unit running for a long time, then the efficiency of cooling or heating will be low or the unit will work abnormally.

Please clean water before use, or use purified water. Make sure the water quality is good enough to keep the unit long-term running in high efficiency.

2. Installation

2.6 Test run



After installation finished, please fulfill the water system with water and purge out air in the system before start-up.

1) Before start-up

Before the unit starts up, a certain number of verifications must be performed on the installation to ensure that the unit will operate under the best possible conditions. The check list below is not exhaustive and should only be used as a minimum reference basis:

- A. Make sure fan rotates freely;
- B. Inspect all water piping for flow direction;
- C. Verify all system piping is correct for operation as per installation requirements;
- D. Check voltage of the unit power supply and make certain voltage is within authorized limitations;
- E. Make sure the unit is properly grounded;
- F. Check the presence of protective and breaking devices;
- G. Check all electric connections for tightness.
- H. Check all piping for leaks and air is well ventilated.



**If everything above is OK, the unit can start up.
If any of them fails, please fix it.**

2) Pre-start up

- A. When the installation of unit is completed, water system pipes are well connected and air purging is done, no leakage or other problems, the unit can be powered to start up.
- B. Turn on the unit, press the on-off button on the operation panel to start the unit. Please check carefully if there is some abnormal noise or vibration, or the display of wired controller is normal or not.
- C. After the unit is working properly for 10 minutes, without any problem, then the pre-start up is completed; If not, please refer to the Service and Maintenance chapter in this manual to solve the problems.



It is suggested not to run "heating" or "hot water" mode, when ambient temperature is over 32 °C, otherwise unit may go into protection mode easily.

3. Usage

3.1 Key icon and display of wire controller

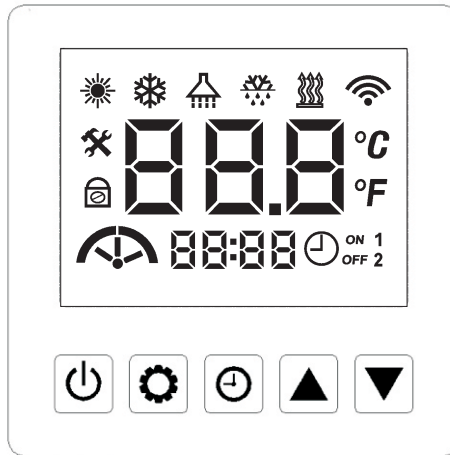

1.1. Icon display in shutdown state:

When power off, it doesn't show all mode icons, and just show the water outlet temperature.

1.2. Mode temperature display under startup:

1) In single mode:

It shows current water temperature for this mode.

2) In dual mode:

When the dual mode is not activated, it shows current water temperature for the hot water mode; When the dual mode is turned on, it shows current water temperature for the current mode.



1.3. Timing icon display on the main interface:

1) The display of the timing icon is related to the current working mode or the mode before power off;

2) When timing is invalid in the corresponding mode, the icon  is full off;

3) When timing is effective in the corresponding mode, the icon  is always on in the main interface;

4) When the timing of the corresponding mode is effective and the current time of the wire controller is within Timer ON period, the icon (**1** or **2**) of the corresponding timing group is always on and the icon **ON** is always on; When the current time is within Timer OFF time, the icon (**1** or **2**) of the corresponding timing group is always on and the icon **OFF** is always on;

5) When the timing in corresponding mode is effective, the icon  is always on, and the icon  is displayed in combination according to the corresponding ON/OFF time:











a. When the current time is within one or two sets of Timer ON period, the icon **ON** is always on, the icon **OFF** is off, and the icon **1** and **2** is always on;

b. When the current time is outside of all Timer ON period, the icon **ON** is off and the icon **OFF** is always on, and the icon(**1** and **2**) is always on;

3. Usage

1.4 Detailed description of icon







Short press: press for less than 1 second; Long press: press for more than 1 second.

Icon	Icon meaning	Icon function description
	Power on / off	1. Power on / off; 2. Unlock; 3. Return to the main interface;
	Setting	1. Set working mode; 2. Enter the user parameter list interface; 3. Set parameters, confirm parameter and set temperature;
	Timing	1. Enter to modify current time; 2. Enter to modify current timer; 3. Change password;
	Add value	1. Enter to change the set temperature; 2. Adjust parameter number and parameter value;
	Decrease value key	1. Enter to change the set temperature; 2. Adjust parameter number and parameter value;
	Combination key 1	Enter password, and it's valid when startup and shutdown;
	Combination key 2	Check parameter lists, and it's valid when startup and shutdown;
	Combination key 3	Turn on the WiFi network quick configuration function, and it's valid when startup and shutdown;
	Combination key 4	Turn on the general configuration function of WiFi network, and it's valid when startup and shutdown;
	Combination key 5	Forced defrosting mode, and it's valid when startup and shutdown;













3. Usage

3.2 Description and function of display icon of wire controller

※ Note: flash slowly: light for 2 seconds, turn off for 1 second, and keep cycling; Flash quickly: on for 0.5 seconds, off for 0.5 seconds, in continuous cycle.

Icon	Icon description	Icon function
	Heating mode	<ol style="list-style-type: none"> 1. The icon is OFF, indicating that there is no heating mode demand; 2. The icon is always ON, indicating that there is a heating mode demand, but the heating mode is not working; 3. The icon flashes slowly, indicating that there is a heating mode demand and the heating mode is working;
	Cooling mode	<ol style="list-style-type: none"> 1. The icon is OFF, indicating that there is no cooling mode demand; 2. The icon is always ON, indicating that there is a demand for cooling mode, but the cooling mode is not working; 3. The icon flashes slowly, indicating that there is a cooling mode demand and the cooling mode is working;
	Hot water mode	<ol style="list-style-type: none"> 1. The icon is OFF, indicating that there is no hot water mode demand; 2. The icon is always ON, indicating that there is a demand for hot water mode, but the hot water mode is not working; 3. The icon flashes slowly, indicating that there is a hot water mode demand and the hot water mode is working;
	Hot water+ heating mode	<ol style="list-style-type: none"> 1. Both icons are OFF, indicating that there is no demand for hot water and heating mode; 2. The hot water icon is always ON, and the heating icon is always ON, indicating that there is a demand for hot water and heating mode, but the unit doesn't enter into the hot water mode or heating mode; 3. The hot water icon is always ON, and the heating icon flashes slowly, indicating that there is a demand for hot water and heating mode, and the unit enters heating mode; <p>The hot water icon flashes slowly, and the heating icon is always on, indicating that there is a demand for hot water and heating mode, and the unit enters hot water mode;</p>
	Hot water+ cooling mode	<ol style="list-style-type: none"> 1. Both icons are OFF, indicating that there is no demand for hot water and cooling mode; 2. The hot water icon is always ON and the cooling icon is always ON, indicating that there is a demand for hot water and cooling mode, but the unit doesn't enter hot water mode or cooling mode; 3. The hot water icon is always on, and the cooling icon flashes slowly, indicating that there is a demand for hot water and cooling mode, and the cooling mode is entered; 4. The hot water icon flashes slowly, and the cooling icon is always on, indicating that there is a demand for hot water and cooling mode, and the hot water mode is entered;
	Defrost status	<ol style="list-style-type: none"> 1. When the icon is OFF, indicating that there is no defrosting demand; 2. When the icon flashes slowly, indicating that the unit is defrosting;
	Auxiliary electric heating status	<ol style="list-style-type: none"> 1. When the icon is OFF, indicating that there is no demand for auxiliary electric heater; 2. When the icon flashes slowly, indicating that the auxiliary electric heater is working;

3. Usage

Icon	Icon description	Icon function
	WIFI	<ol style="list-style-type: none"> When the WiFi configuration function starts, the icon flashes, indicating that the WiFi network is being configured; When WiFi configuration function doesn't start up: When the WiFi module is successfully connected to the server, the icon is always ON, indicating that the connection with the server is normal; When the WiFi module and the server are not connected successfully, the icon goes OFF, indicating that the WiFi network is not configured; When the WiFi configuration is successful, but the communication with the server has problem (there is no communication for 5 minutes), the icon flashes slowly, indicating that the line controller is disconnected from the server;
	Parameter	<ol style="list-style-type: none"> In the main interface, when the icon goes off, the display doesn't show a parameter; In the parameter list, when the parameter is modified, the icon flashes slowly; When checking the parameters and operation status, the icon is always on;
	Lock key	<ol style="list-style-type: none"> The wire controller has no operation for 60 seconds. The icon is ON, and all icons and key lights are off, indicating that it enters the screen saver state; In the screen saver state, press any key, the "on / off" button light and the screen are ON (at this time, except for the "on / off" button, other keys are invalid), and after no operation for 30 seconds, and it enters the screen saver state again; Long press the "on / off" key for 5 seconds, the icon goes off, and all key lights are ON, indicating that the screen saver exits, and the wire controller can operate normally;
	Numeric icon	<ol style="list-style-type: none"> Show the current temperature according to the current working mode; In the parameter list and the operation state list, the corresponding parameter value and the operation state value are displayed; When displaying the temperature value, it shall be accurate to one decimal. Show the list serial number for Timer.
	Normal operation and low noise operation	<ol style="list-style-type: none"> All the icons are off, indicating that the fan is not running; Only the left half of the icon is light, means that the fan is running with low noise; The icon is fully light, means that the fan is running at rated speed;
	Compressor operation	<ol style="list-style-type: none"> All the icons are off, indicating that the compressor is not running; Only the left part of the icon  is always on, and other parts are off, indicating that the compressor operates at low speed; The middle of the icon  is always on, and the others are off, indicating that the compressor operates at medium speed; The right part of the icon  is always on, and the others are off, indicating that the compressor operates at high speed;
	Water pump operation	<ol style="list-style-type: none"> The icon goes off, indicating that the water pump is not running; The icon is always on, indicating that the water pump is running;
	Clock	<ol style="list-style-type: none"> In the main interface, when the clock is set, it will be shown in 24 hours; In the parameter list, the corresponding parameter serial number is shown; In the timing list, the list parameter values are shown;
	Timing icon	<ol style="list-style-type: none"> Set timing time

3. Usage

3.3 Operating instructions for the wire controller

3.1. Startup / shutdown operation:

1) Screen saver status:



(Screen saver status)



a. Press any key, the screen of the wire controller will light up, press the key  for 5 seconds, and the wire controller will be unlocked and exit the screen saver state;



(Screen lights up)



(Unlock)

b. If the wire controller is in the OFF state, short press the key  to start the wire controller; If the wire controller is in the ON state, short press the key  to shut down the wire controller;



(Shutdown interface)





(Startup interface)

3. Usage



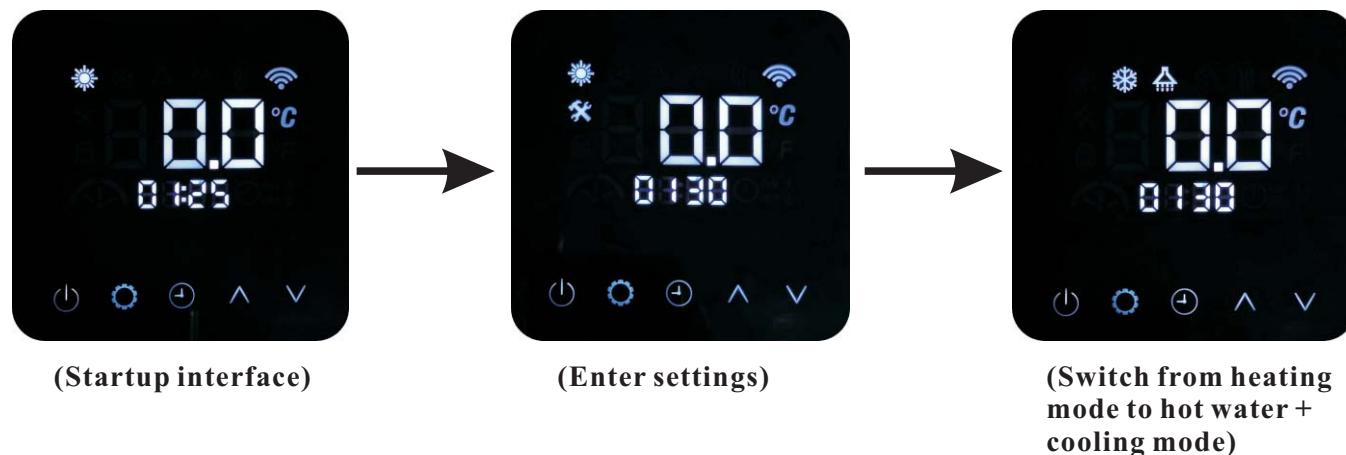



3.2 Operation of working mode:

When the wire controller is in the startup state, short press  on the main interface to enter the working mode.



The icon of the current working mode is always ON, and the three digits in the temperature display area display the current temperature of the corresponding selected mode. The icon  flashes slowly, and short pressing key continuously to choose the working mode. After the operation mode is selected, if there is no key operation for 3 seconds, the mode is confirmed, and exit the operation mode setting interface.



The sequence of working mode is shown in the following table:

Operation mode	Display icon
Heating mode	
Cooling mode	
Hot water mode	
Hot water + heating mode	 + 
Hot water + cooling mode	 + 

3. Usage

3.3 Operation of setting temperature:





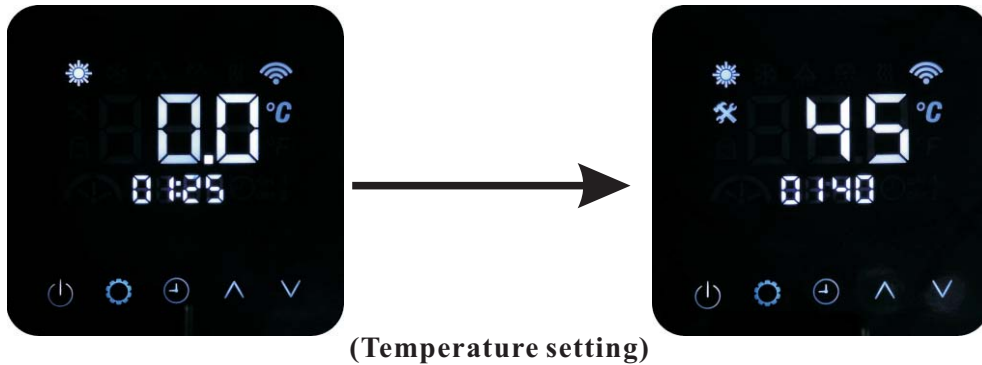

1) Enter the setting temperature modification interface:

When the wire controller is in the startup state, short press the key  or key  on the main interface to enter the temperature setting modification for the current working mode. At this time, the three-digits in the temperature display area displays the setting temperature of corresponding mode, which flashes slowly. The corresponding mode icon is always ON, while the other mode icons are off, and the icon  flashes slowly.











2) Operation of setting temperature modification:

① In single mode:

After entering the set temperature modification interface, short press the key  or key  to adjust the corresponding set temperature value one by one. At this time, the temperature value and the icon  flash slowly. After long pressing the key  or key  for 2 seconds, the temperature value is increased or decreased by 1°C every 0.5 seconds. At this time, the temperature value and the icon  are always ON. After releasing, it flashes slowly, and press the key to save the setting and exit;

② In dual mode:

After entering the set temperature modification interface, short press the key  or key  to adjust the corresponding set temperature value one by one. At this time, the temperature value and the icon  flash slowly. After long pressing the key  or key  for 2 seconds, the temperature value is increased or decreased by 1°C every 0.5 seconds. At this time, the temperature value and the icon  are always ON. After releasing, it restart to flash slowly; After the modification is completed, short press the key  to save the set temperature value, and switch to another mode. At this time, the original mode icon is off, the other mode icon is always on, the three-digits in the temperature display area of the display screen shows the corresponding mode temperature and flashes slowly, press the key  to switch back to the previous mode again to modify the set temperature value, and press the key to save and exit;



(-1°C)





(Temperature setting)



(+1°C)

3. Usage

3) Exit of setting temperature modification interface:

- a. During the modification process, short press the key  to save the value and exit to the main interface, and the icon  goes off;
- b. During the modification process, if there is no key operation for 30 seconds, the value will be saved and exit to the main interface, and the icon goes off;

4) Heating curve function:

When the heating curve is invalid, the heating set water temperature is a fixed value;

When the heating curve is activated, the heating set water temperature is a dynamic value, which changes with the outdoor ambient temperature;

Under different ambient temperatures, the demand for heating water temperature is different. The lower the ambient temperature, the higher the demand for heating water temperature. On the contrary, the higher ambient temperature, the lower demand for heating water temperature. In different range of temperature, Therefore, the curve function sets five temperature nodes, and different outdoor temperatures correspond to different set temperature for heating. Heating curve can help to get set water temperature automatically, and make heat pump get higher COP, as well as make the house more comfortable.

The outdoor temperature node and the corresponding water temperature are set by parameters.

The outdoor temperature range is the heating working environment(-20°C~45°C) Water temperature setting range is(20°C~65°C).

Heating curve operation:

In parameter list for heating curve, parameter 19/21/23/25/27 is used to set 5 different ambient temperature:

Ambient temperature of heating curve point 1(HCTA1)

Ambient temperature of heating curve point 2(HCTA2)

Ambient temperature of heating curve point 3(HCTA3)

Ambient temperature of heating curve point 4(HCTA4)

Ambient temperature of heating curve point 5(HCTA5)

Parameter 20/22/24/26/28 is used to set 5 corresponding set temperature:

set water temperature of heating curve point 1(HCTs1) ;

set water temperature of heating curve point 2(HCTs2) ;

set water temperature of heating curve point 3(HCTs3) ;

set water temperature of heating curve point 4(HCTs4) ;

set water temperature of heating curve point 5(HCTs5) ;

3. Usage

Curve function parameter list			
No.	Curve node	Range	Defaults
19	Ambient temperature of heating curve point 1	-20°C~45°C	-20
20	Setwater temperature at heating curve point 1	20°C~65°C	42
21	Ambient temperature of heating curve point 2	-20°C~45°C	-7
22	Setwater temperature at heating curve point 2	20°C~65°C	35
23	Ambient temperature of heating curve point 3	-20°C~45°C	2
24	Setwater temperature at heating curve point 3	20°C~65°C	31
25	Ambient temperature of heating curve point 4	-20°C~45°C	7
26	Setwater temperature at heating curve point 4	20°C~65°C	28
27	Ambient temperature of heating curve point 5	-20°C~45°C	12
28	Setwater temperature at heating curve point 5	20°C~65°C	25

Then the controller will create a heating curve according to the settings, to reach set water temperature automatically according to actual outdoor temperature.

The following describes the heating curve: (the ordinate is the set water temperature, and the abscissa is the outdoor ambient temperature)

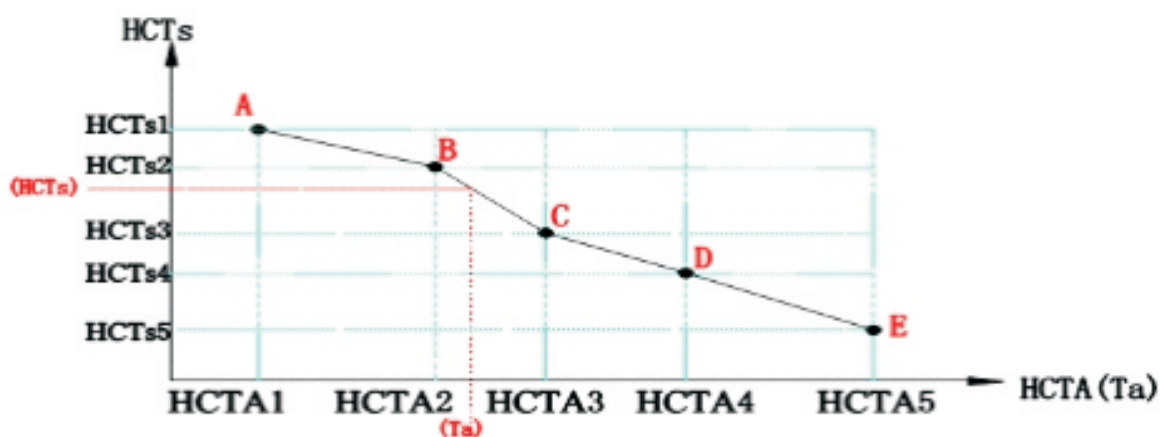

3. Usage

(HCTA1~HCTA5) must meet: (HCTA1) < (HCTA2) < (HCTA3) < (HCTA4) < (HCTA5)

If the user sets wrongly in the input process, the controller can automatically correct it.

a. When the heating curve is activated:

The set temperature is changed automatically according to outdoor temp.. If user don't want this set temperature, it can be changed manually according to Chapter 3.3. And system will calculate the difference between the manual set value and the set temp. from heating curve, and adjust the heating curve according to the difference.

If set temperature in heating curve is 35°C user don't want this temp., then he can set temp. manually to 40°C and heating curve will be adjusted automatically according to the difference (40-35)=5°C, and increase all the set temperatures by 5°C in the curve. At this time, the set water temperature range of the heating mode is 25°C~60°C.

b. When the heating curve is closed:

The set temperature range of heating mode is: 25°C~55°C;



The set temperature range of refrigeration mode is: 12°C~25°C;

The set temperature range of hot water mode is: 25°C~55°C;





3.4 Modification of system time:

(fixed 24-hour display)





1) Enter the system time modification interface:

When the wire controller is in the startup or shutdown state, short press the key  on the main interface to enter the system time modification interface. At this time, the hour part of the clock display area will flash slowly, the icon  will flash slowly, and the minute part of the clock display area will always be on;

2) system time modification:

a. When the hour part of the clock display area is flashing slowly, short press the key  or key  can adjust the hour value (00 ~ 23, cycle) one by one. Or, long press the key  or key  for 2 seconds, the hour will be increased or decreased by 1 hour every 0.5 seconds. At this time, the hour part of the number will change from slow flashing to constant flashing, and come back to the slow flashing after release;

b. After setting the hour part, short press the key  to enter the setting of the minute part. At this time, the number of the hour part in the clock display area is always on, and the minute part is flashing slowly;

c. When the minute part of the clock display area is flashing slowly, short press the key  or key  is used to adjust the minute value (00 ~ 59, cycle). or long press the key  or key , the minute will be increased or decreased by 1 minute every 0.5 seconds. At this time, the minute part of the number changes from slow flash to constant light. After releasing, it comes back to slow flash;

3. Usage



(Enter settings)





(Add one hour)



(Add one minute)

d. After setting the number of minutes, short press the key  to save the current setting and exit to the main interface;



3) Exit of system time modification interface:

a. During the modification process, short press the key  to save the data and exit to the main interface, and the icon  goes off;

b. During the modification process, if there is no key operation for 30 seconds, the data will be saved and exit to the main interface, and the icon  goes off;

3.5. Query and setting of user parameters:

1) Enter the user parameter list interface:

When the wired controller is in the power ON or OFF state, long press the key  for 5 seconds on the main interface to enter the user parameter list interface, and it is in the query state. At this time, the parameter serial number "01" in the clock display area is always on, and the three digits in the temperature display area of the wire controller is always on, and the icon  is off;





(Start interface)









(Parameter list interface)

3. Usage



2) User parameter modification and query:

a. Short press the key  or key  to adjust the parameter serial number in one cycle and query each parameter;



b. Select the target parameter to be modified. Short press the key  to enter the modification state. The parameter value of the parameter is always ON and the icon  flashes slowly. At this time, short press the key  or key  to modify the current parameter value step by step. Or, long press the key  or key , parameter value will be increased or decreased by 1 in every 0.5 seconds;



(Parameter modification interface)

c. In the modification state, short press the key  to save the change and return to the query state. The parameter value is always on and the icon  changes from slow flashing to off;

3) Exit of user parameter modification and query:

a. In the process of modification or query, short press key  to save the data and exit the main interface, and the icon  goes off;

b. In the process of modification or query, if there is no key operation for 30 seconds, the data will be saved and exit to the main interface, and the icon  goes off;

User parameter list			
No.	Curve node	Range	Defaults
1	Reserved	/	0
2	Hot water restarts based on water ΔT	0°C~10°C	5
3	Heating restarts based on water ΔT	0°C~10°C	2
4	Cooling restarts based on water ΔT	0°C~10°C	2
5	Reserved	/	0

3. Usage

User parameter list			
No.	Curve node	Range	Defaults
6	Heat pump low noise mode	0--off;1--on	0
7	Reserved	/	20
8	Reserved	/	25
9	Reserved	/	2
10	Heating balance function	0--off;1--on	0
11	Ambient temperature of heating balance startup	-15°C~15°C	-29
12	Heating balance restarts based on water ΔT	3°C-20°C	5
13	Max. working hours of heating	20-180(minute)	20
14	Min. working hours of hot water	20-180(minute)	50
15	Reserved	/	25
16	Heating curve function	0--off;1--on	1
17	Reserved	/	0
18	Reserved	/	10
19	Ambient temperature 1	-20°C~45°C	-20
20	Set water temperature 1	20°C-65°C	42
21	Ambient temperature 2	-20°C~45°C	-7
22	Set water temperature 2	20°C-65°C	35
23	Ambient temperature 3	-20°C~45°C	2
24	Set water temperature 3	20°C-65°C	31
25	Ambient temperature 4	-20°C~45°C	7
26	Set water temperature 4	20°C-65°C	28
27	Ambient temperature 5	-20°C~45°C	12
28	Set water temperature 5	20°C-65°C	25
29	Reserved	/	0
30	Whether the screen saver shows water outlet temperature	0:Do not show,1:Show	0

3. Usage

3.6. Running status parameter query:

1) Entry of running state parameter list:

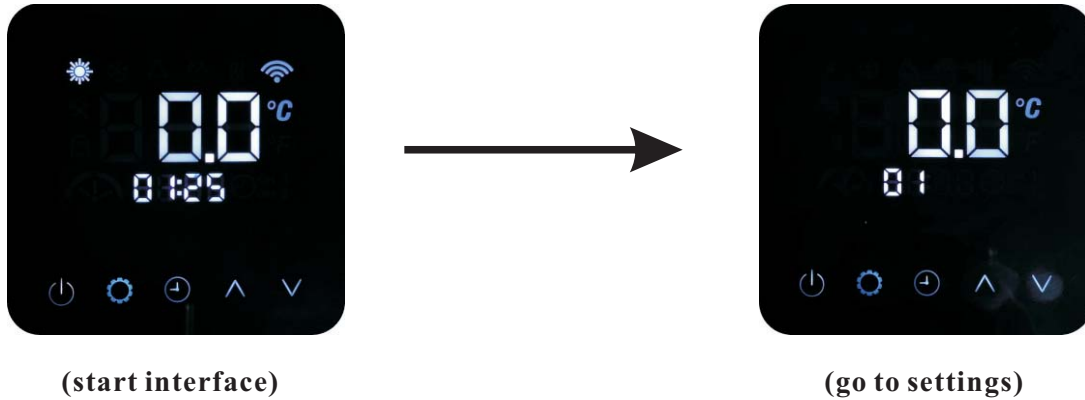

When the wired controller is in the power-on or power-off state, press the key and the key at the same time on the main interface for 5 seconds to enter the query state of running state. At this time, the corresponding parameter number "1" will be displayed in the clock display area, which is always on, and the corresponding parameter value is displayed in the temperature display area, which is always on, the icon is off.

2) Entry of running state parameter list:

Short press the key or the key to adjust the parameter serial number in cycle, and query each parameter

3) Exit of the running state parameter list:

- a. During the query process, short press the key to exit to the main interface, and the icon goes off.
- b. During the query process, if there is no operation for 30 seconds, it will exit to the main interface, and the icon will turn off.

List of system operating parameters			
S/N	Meaning	S/N	Meaning
1	Ambient temperature	7	Inlet water temperature
2	Hot water temperature	8	Tank temperature (displays 0)
3	Heating temperature	9	Indoor coil temperature
4	Cooling temperature	10	System voltage
5	Room temperature	11	System current
6	Outlet water temperature	12	System compressor frequency

3. Usage

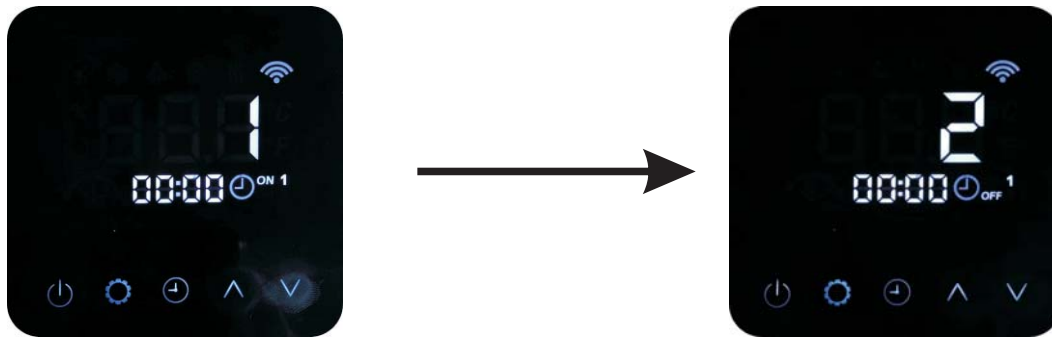

(Show ON 1)

(Show OFF 1)

b. Select the target parameter to be modified, short press the key  to enter the modification state



(Parameter modification interface)

a). When the selected parameter is timer function switch (0 or 1):

The three-digits in the temperature display area shows the serial number of the parameter, which is always on, the parameter value in clock area is always on, and the icon  flashes slowly.

b). When the selected parameter is a time value:





The serial number of the parameter shows in the temperature area, which is always on. The hour and minute parts of the timer displays at clock area, and always on, and the icon  flashes slowly.

c. in the modified state

a). When the modified parameter is timer function switch:

When the icon  flashes slowly, short press the key  or key  to adjust the corresponding switch value (0 or 1).

b). When the modified parameter is a time value



When the icon  flashes slowly, shortly press the key  or key  to adjust the timer step by step. Each short press, the timing time increases or decreases by 30 minutes, in one cycle of 00:00~23:30. Keep on press the key  or key , timer will be increased or decreased by 30 minutes every 0.5 seconds;

3. Usage

d. In the modification state, short press the key  to confirm the setting of the parameter value, and return to the query state, the parameter value remains on and the icon  changes from slow flashing to off;



2) Exit of timing function parameter list::

a. In the process of modification or query, shortly press the key  to save the data and exit to the main interface, the icon  goes off.

b. During the modification or query process, if there is no key operation for 30 seconds, the data will be saved and exit to the main interface, the icon  will turn off.

Timed list			
S/N	Meaning	Range	Default
00	Heating timer function switch	0--invalid,1--valid	0
01	Heating timer 1 ON time	00 00-23 30	00 00
02	Heating timer 1 OFF time	00 00-23 30	00 00
03	Heating timer 2 ON time	00 00-23 30	00 00
04	Heating timer 2 OFF time	00 00-23 30	00 00
05	Cooling timer function switch	0--invalid,1--valid	0
06	Cooling timer 1 ON time	00 00-23 30	00 00
07	Cooling timer 1 OFF time	00 00-23 30	00 00
08	Cooling timer 2 ON time	00 00-23 30	00 00
09	Cooling timer 2 OFF time	00 00-23 30	00 00
10	Hot water timer function switch	0--invalid,1--valid	00 00
11	Hot water timer 1 ON time	00 00-23 30	00 00
12	Hot water timer 1 OFF time	00 00-23 30	00 00
13	Hot water timer 2 ON time	00 00-23 30	00 00
14	Hot water timer 2 OFF time	00 00-23 30	00 00
15	Low-noise timer function switch	0--invalid,1--valid	0

3. Usage

Timed list			
S/N	Meaning	Range	Default
16	Low-noise timer 1 ON time	00 00-23 30	00 00
17	Low-noise timer 1 OFF time	00 00-23 30	00 00
18	Low-noise timer 2 ON time	00 00-23 30	00 00
19	Low-noise timer 2 OFF time	00 00-23 30	00 00

※※Attention※※

1. In the same mode, if two sets of TIMER are set and the timer ON~OFF period is overlapped, the timer is just valid in first set.
2. When the timer function switch = 0, the timer is invalid.
3. After the timer function switch is set to 1, the unit will work in corresponding working mode in the timer ON period of this mode.
4. After the low-noise timer function switch is set to 1, the unit will work in the low-noise function only in the low-noise timer ON period.

3. Usage

3.8 WIFI Functions:

New website application(AMT customer level)

1.Network diagram of customers、 installers and users

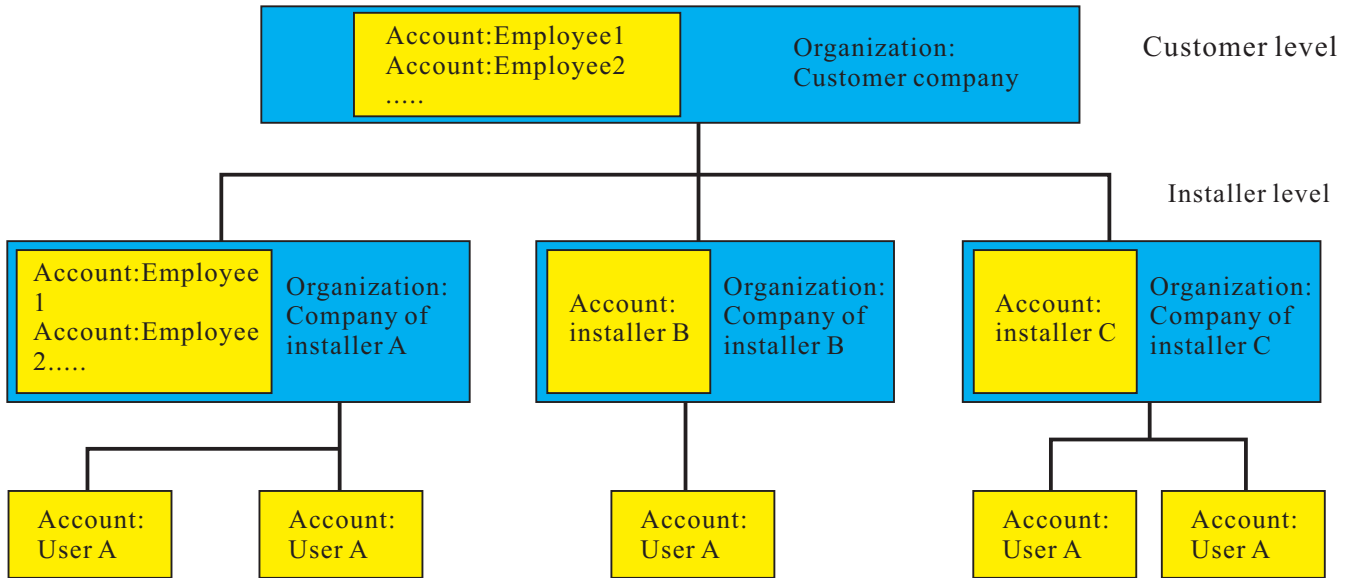

Note:

Organization: The organization framework includes two levels.

Customer level: Created by AMITIME company based on customer name

There is only one customer level, and many installers can be set under it;

Installer level: It is created by the customer according to the name of its subordinate installer (if the customer has no installer, it also needs to create one (the name is defined by the customer));

There can be many installers at installer level, and many users under the installer level at the same time.

Account: The login account number under each organization (when it is first created, the default password is 123456)

Customer account:

- 1、 Its account number and password are created by AMITIME according to the requirements of the customer's name, and set it as the Administrator of this company. As the administrator of its company, one can add more accounts for his employees, which has the full rights as administrator's account, except creating other accounts for this company (can create and edit installer's level organization and accounts)
- 2、 Customer can view or set the unit data information of any installer and their users.
- 3、 After logging in (using the account provided by AMT), the customer can recreate an account of the same level for management use.
- 4、 Create the account number of each installer.

Installer account:

- 1、 Its account number and password are created by customer for the installer;
- 2、 installers can view or set any user level unit data information under it;
- 3、 After logging in (using the account number provided by the customer), the installer can recreate an account with the same level for management use;
4. Create user accounts, and each user account can be bound to one or more heat pumps (each heat pump should be equipped with WiFi module)

User level: 1、 Its account number and password are created by installer.

Users can only view and set the operating parameters of the bounded heat pump unit.

3. Usage

Organization and account creation steps

1.Organization creation of installer level

- 1.1 Use the browser to log in to the website: <http://www.myheatpump.com>
- 1.2 Log in to the system with the account and password provided by AMT(123456 by default)
- 1.3 At this time, the prompt of changing the original password will pop up. You can click Cancel and modify the password under the account name later.

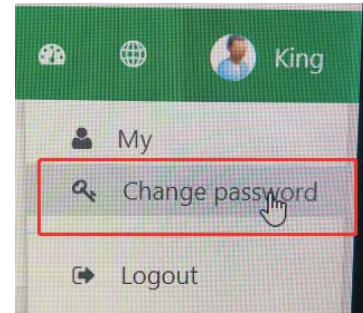
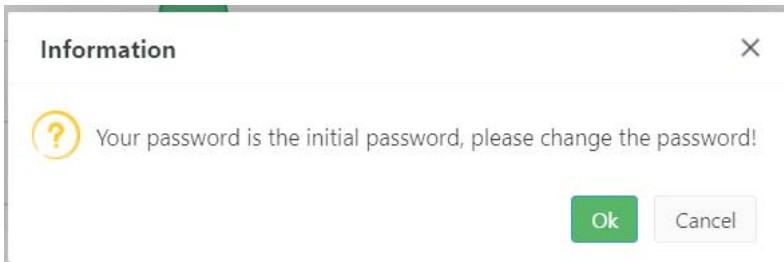

1.4 Add new installer

1.4.1 See below, choose Organization manage, click “AMT” and then choose “+New”

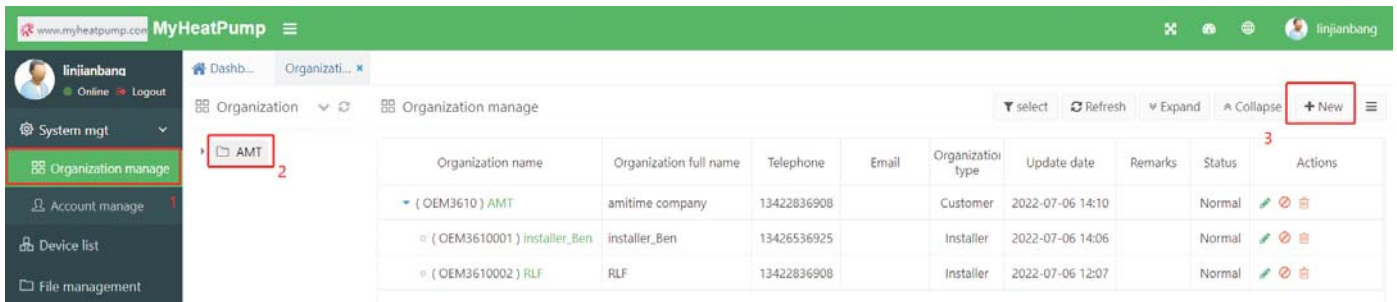

1.4.2 After step 1.4.1 the following interface will pop up, and pls fill in according to the following sequence number.

Contents not marked with an asterisk are not necessary;

Contents marked in gray will be automatically filled in by the system

1. Organization name: Fill in the company name or installer name of the installer;
2. Organization full name: Fill in the full name of the installer
3. Principal: Fill in the person in charge for the installer
4. Telephone: Fill in the installer's phone no. (This tel no. should be the same one used to register account)
5. Upload LOGO: The company logo image can be uploaded. No size limitation for the image, the system automatically zooms it.
6. Save: After finishing all above settings, click save.

3. Usage

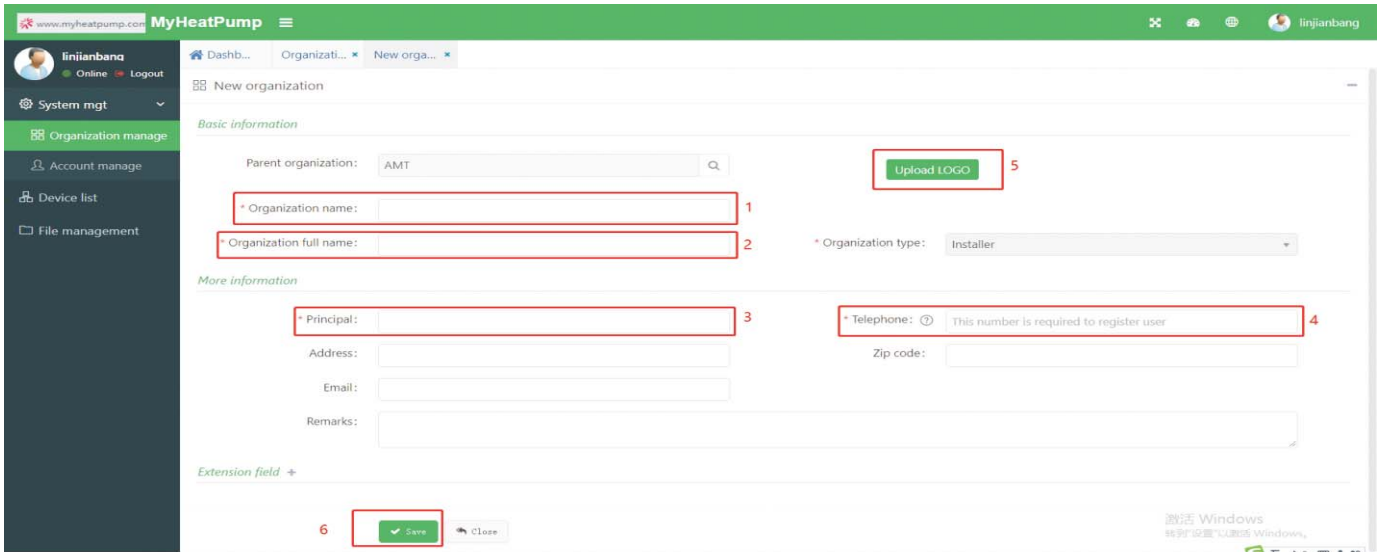

1.4.3 When the setting is saved, the installer organization account is successfully created like below.

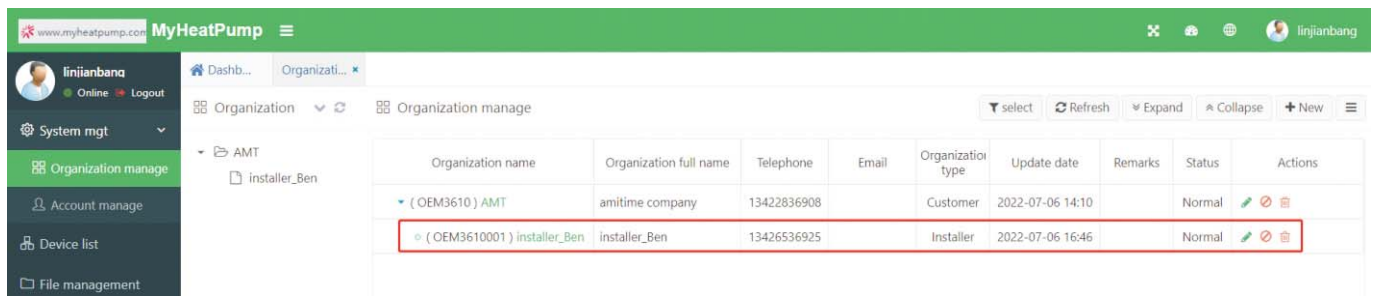

2.Account creation(Customer account, installer account and user account)

2.1 Administrator of a organization can follow below steps to create a account for his employees to use:

Choose the account type and apply

2.1.1 +Customer:Click to apply for customer level account

2.1.2 +Installer:Click to apply for installer level account

2.1.3 +User:Click to apply for user level account

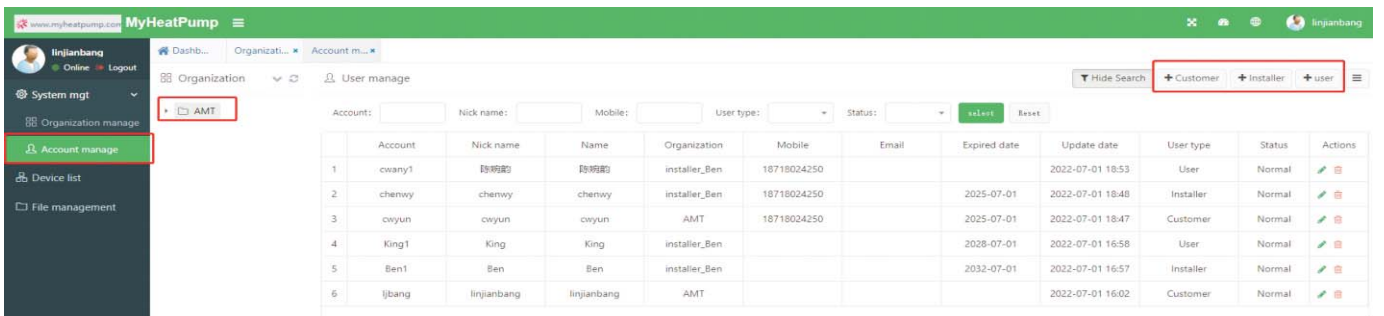

3. Usage

2.2 The account creation interface of customer is shown in the following figure (if multiple accounts are not required, the operation on this point can be ignored).

2.2.1 Organization: Select a company, and only one fixed company.

2.2.2 Account: Fill in the second account name that need to login customer level

2.2.3 Nick name: Fill in the name of the customer (only for comments)

2.2.4 Expired date: Select the valid time

2.2.5 Role name: Select permissions of the account (Sales can only view the terminal devices, and admin can also modify related information)

2.2.6 Save: Save the settings, and another new account for customer level is created.

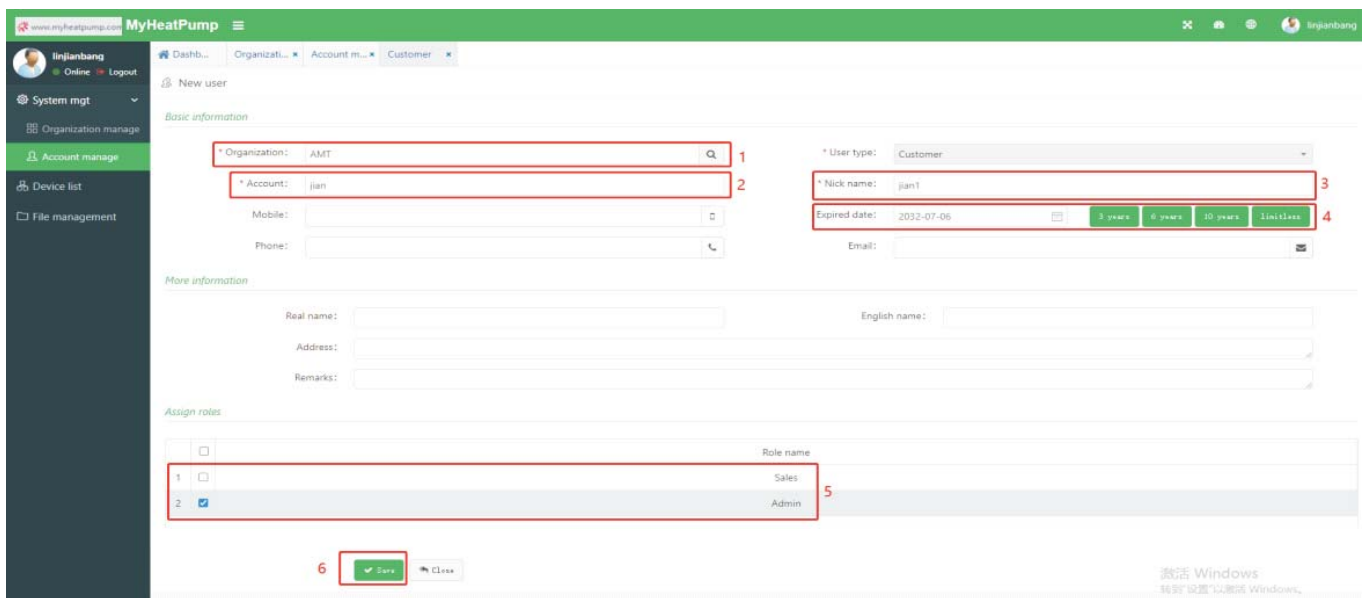

2.3 The account creation interface of installer is shown in the following figure.

2.3.1 Organization: Choose installer, and only installer can be chosen.

2.3.2 Account: Fill in the first account name installer level

2.3.3 Nick name: Fill in the name of the installer (only for comments)

2.3.4 Expired date: Select the valid time;

2.3.5 Role name: Select permissions of the account (Sales can only view the terminal devices, and admin can also modify related information)

2.3.6 Save: Save the settings, and a new account for installer level is created.

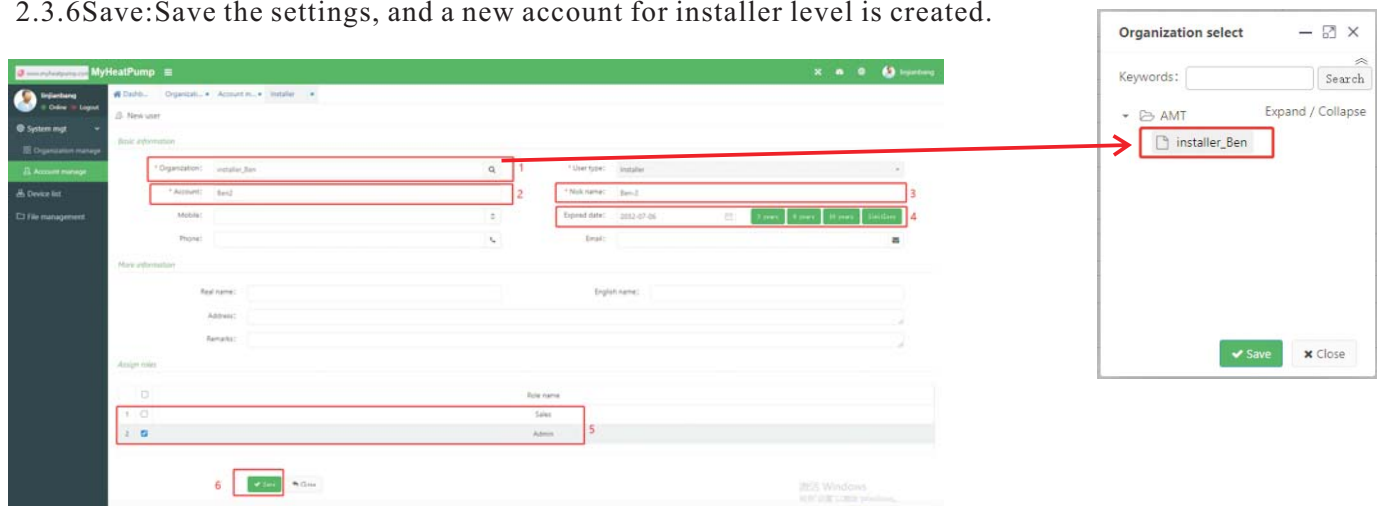

3. Usage

2.4 The account creation interface of user is shown in the following figure.

2.4.1 Organization: Choose installer, and only installer can be chosen.

2.4.2 Account: Fill in the account name of the terminal user used to login website or app

2.4.3 Nick name: Fill in the name of the users (only for comments)

2.4.4 Role name: Select permissions of the account (On the website, users can only view unit information of bounded heat pump)

2.4.5 Save: Save the settings, and a new account for user level is created.

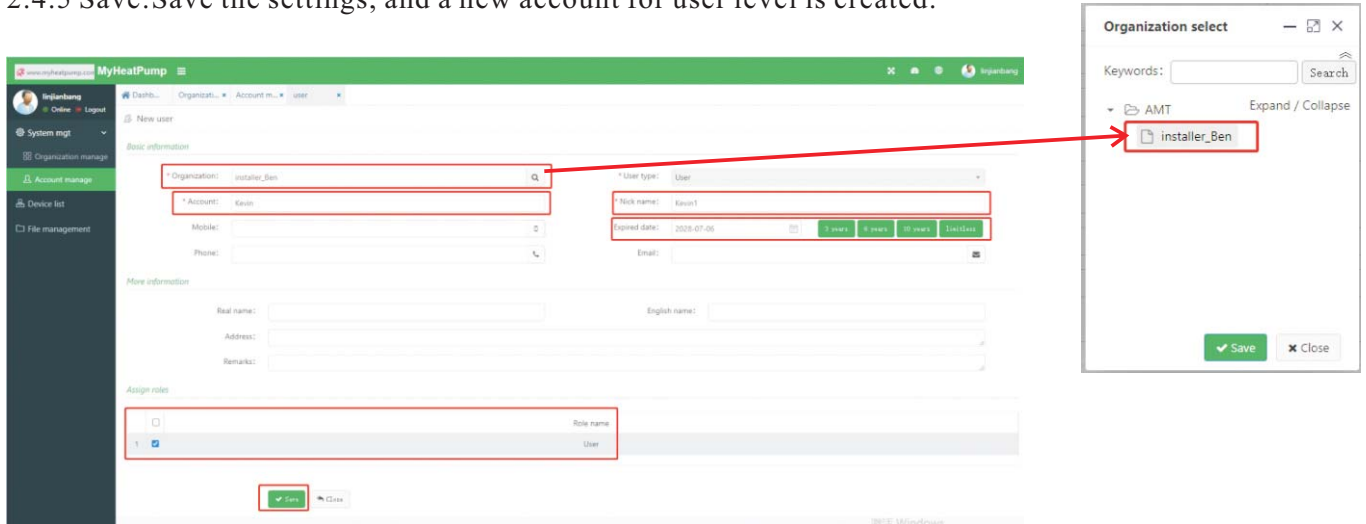

2.5 After finishing above steps 2.2、 2.3 and 2.4 three types of login accounts can be created (the default password is 123456).

Customer account: Allow to create three types of accounts--Customer account, installer account and user account.

Installer account: Allow to create two types of accounts--Installer account and user account.

User account: only allow to log in to view the unit information and bind the equipment.

3. Usage

3.Organization creation of installer level

3.1 Download APP via phone,log in website:http://www.myheatpump.com, use the scanning function of the browser,and scan the QR code at the bottom right of the web page to download and install the app;

3.2 After installing the APP,if the user account has been created on the website, just enter the account and password directly in the login interface

If no account is created on the website, user can click Register on the APP and create a user account according to the instruction;

3.2.1 Register new account in APP

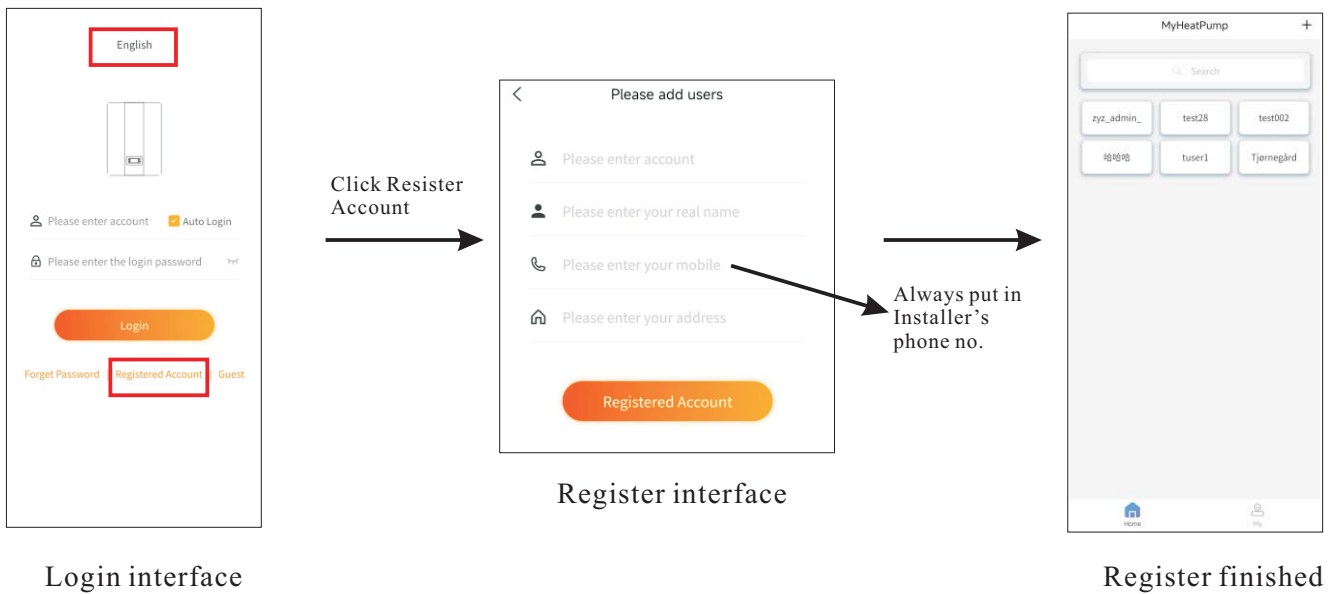

3. Usage

4.Binding for heatLITE series operation panel

4.1 Connect the mobile phone to the WiFi of the router, and then enter the operation panel binding mode (in the unlocked state, press the “shutdown key” + “down key” at the same time)

At this time, the WiFi icon of the operation pane flashes;

Method 1:Bind units in APP automatically.

Open the app in your mobile phone and perform the following operations after logging in

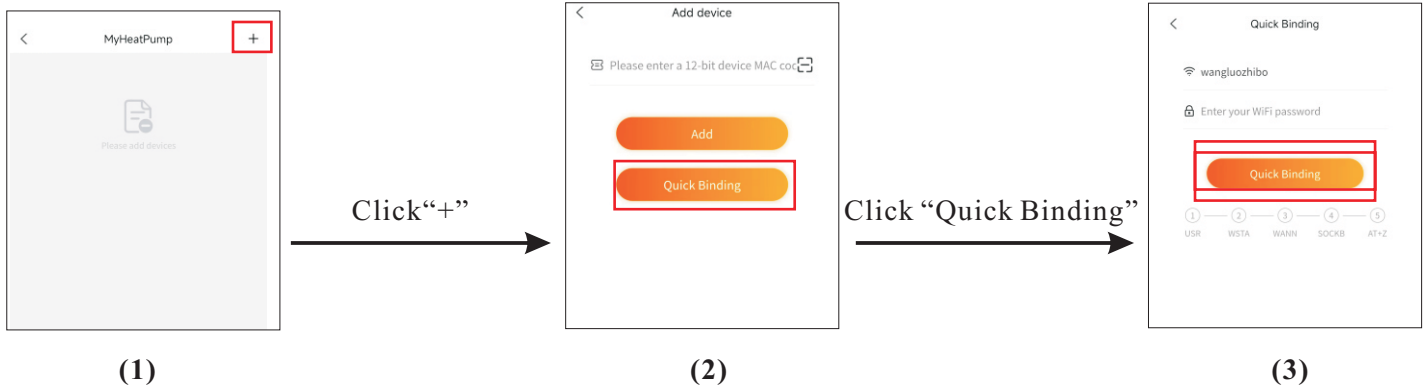

Input wifi password connected Scan the QR code with the mobile browser, and the download guide will pop up automatically. Download and install APP according to the operating instructions. Click “Quick Binding”

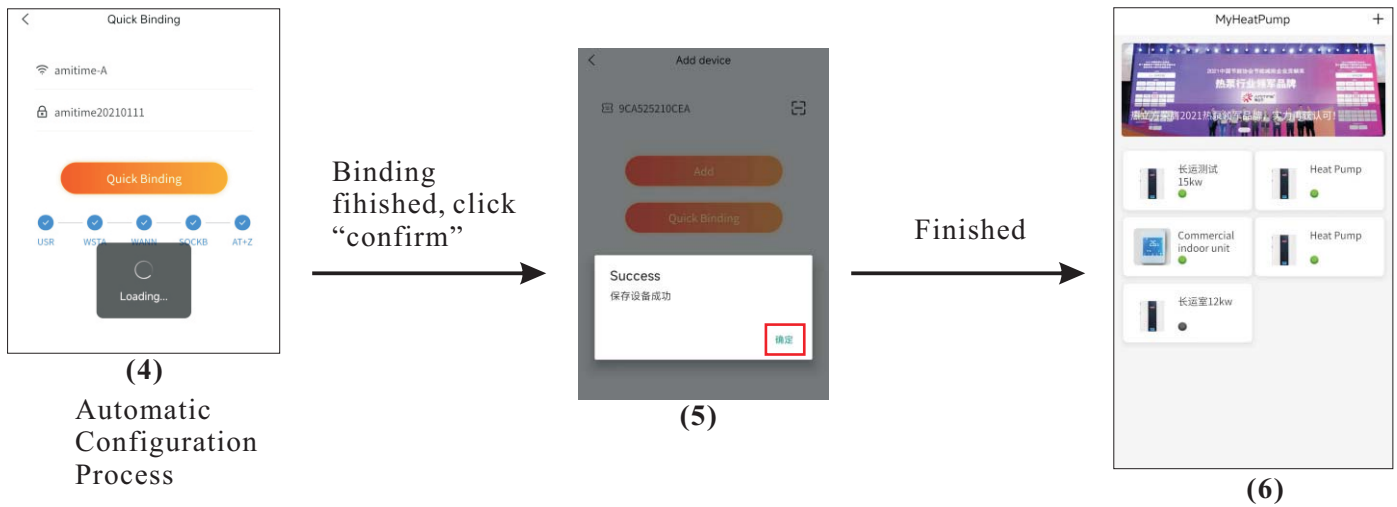

If the interface keeps loading for more than 2 minutes during the configuration Process, then it means the configuration fails, Please reconfigure it once or manually configure it according to method 2



3. Usage

Method 2: If method 1 failed, bind it by manually entering the MAC address as follows.

Step 1: When the WiFi icon of the operation panel is flashing, connect mobile phone with the WiFi module, then configure WiFi according to the following steps.

1. Turn on your computer or mobile phone WIFI setting, check WIFI ‘USR-C210’ and connect it.



2. Turn on the browser and input 10.10.100.254



3. Use account “admin” and password “admin” to log-in the webpage, then please press “log-in” to confirm the log-in.,



3. Usage

4. You can set the language to English by pressing the button “English” on the upper right corner.



5. Referring to the following drawing, press “WiFi Setting”, please set ‘AP Mode’ to ‘STA Mode’.

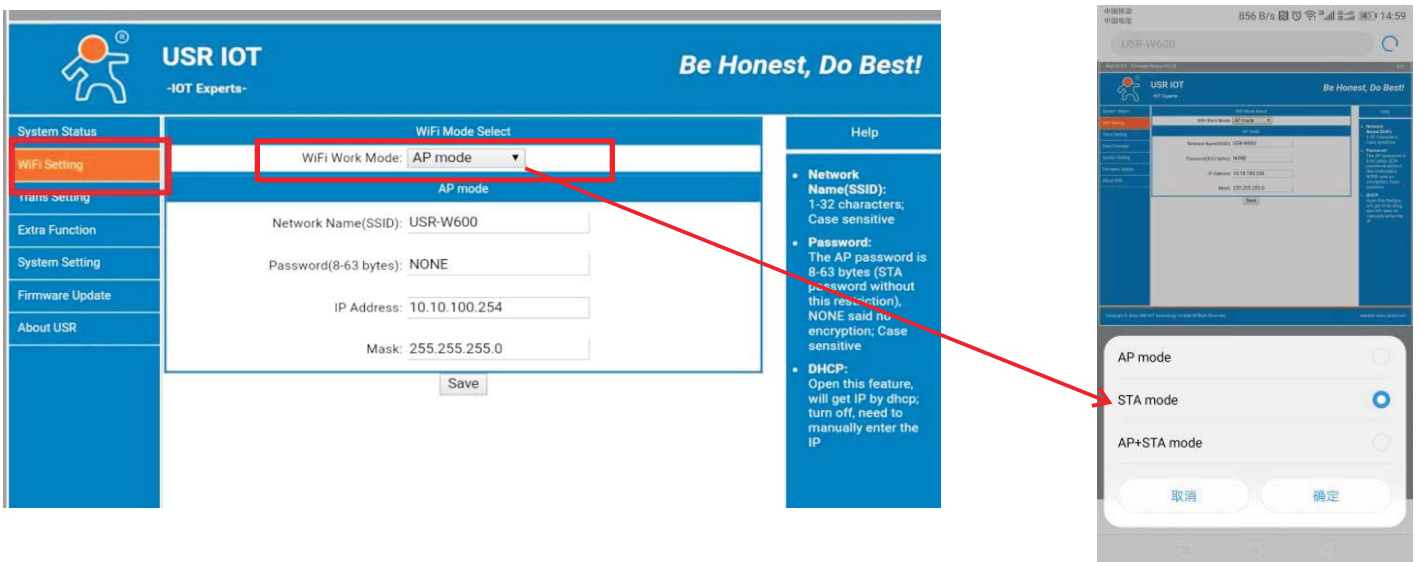

6. Press “Search” to search the WIFI which can be connected (the wifi that the device should be connected. In a way, the WIFI of your home or office, that is connected to the internet).

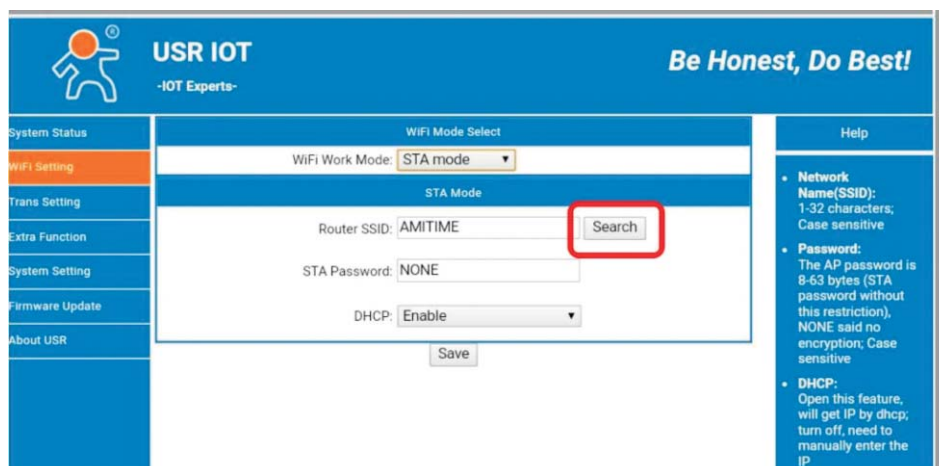

3. Usage

7. Choose the WIFI which will be connected and confirm.

The screenshot shows the USR IOT web interface. The top header includes the logo, 'USR IOT -IOT Experts-', and the slogan 'Be Honest, Do Best!'. A left sidebar contains menu items: System Status, WiFi Setting (highlighted), Trans Setting, Extra Function, System Setting, Firmware Update, and About USR. The main content area is titled 'Please select a SSID' and contains a 'Site Survey' table with the following data:

SSID	BSSID	RSSI	Channel
AMITIME	30:7B:AC:AE:8D:D0	-91	11

Below the table are 'OK' and 'Refresh' buttons. A 'Help' sidebar on the right provides instructions for Network Name (SSID), Password, and DHCP settings.

8. If the WIFI you choose need password, input the WIFI password in key position as below picture. Please remember to press “Save” to confirm the setting.If WiFi is not found, set up manually.

The screenshot shows the 'WiFi Mode Select' configuration page. The 'WiFi Work Mode' is set to 'STA mode'. Under the 'STA Mode' section, the 'Router SSID' is 'AMITIME' with a 'Search' button. The 'STA Password' field is highlighted with a red box and contains the text 'NONE'. The 'DHCP' setting is 'Enable'. A 'Save' button at the bottom is also highlighted with a red box. The 'Help' sidebar on the right provides instructions for Network Name (SSID), Password, and DHCP settings.

3. Usage

9. Choose and enter “Trans Setting” on the left of the page.

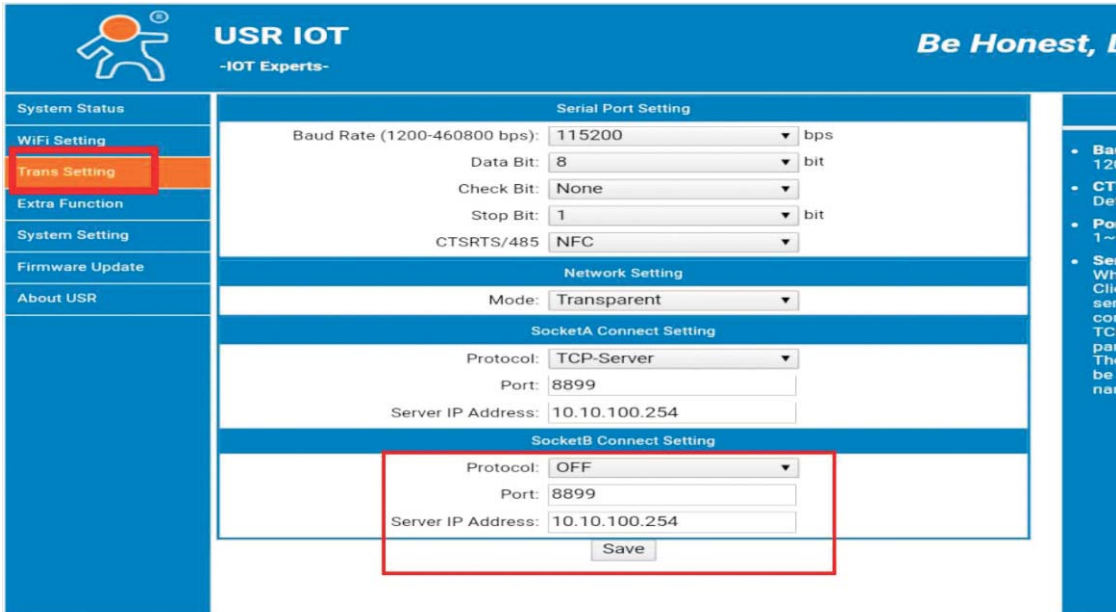

10. Set Socket B from ‘OFF’ to ‘TCP-Client’ in below page. Set the Port as “18899”. Set the Server IP Address as “www.myheatpump.com”. Then please remember to press “Save” to confirm the setting.

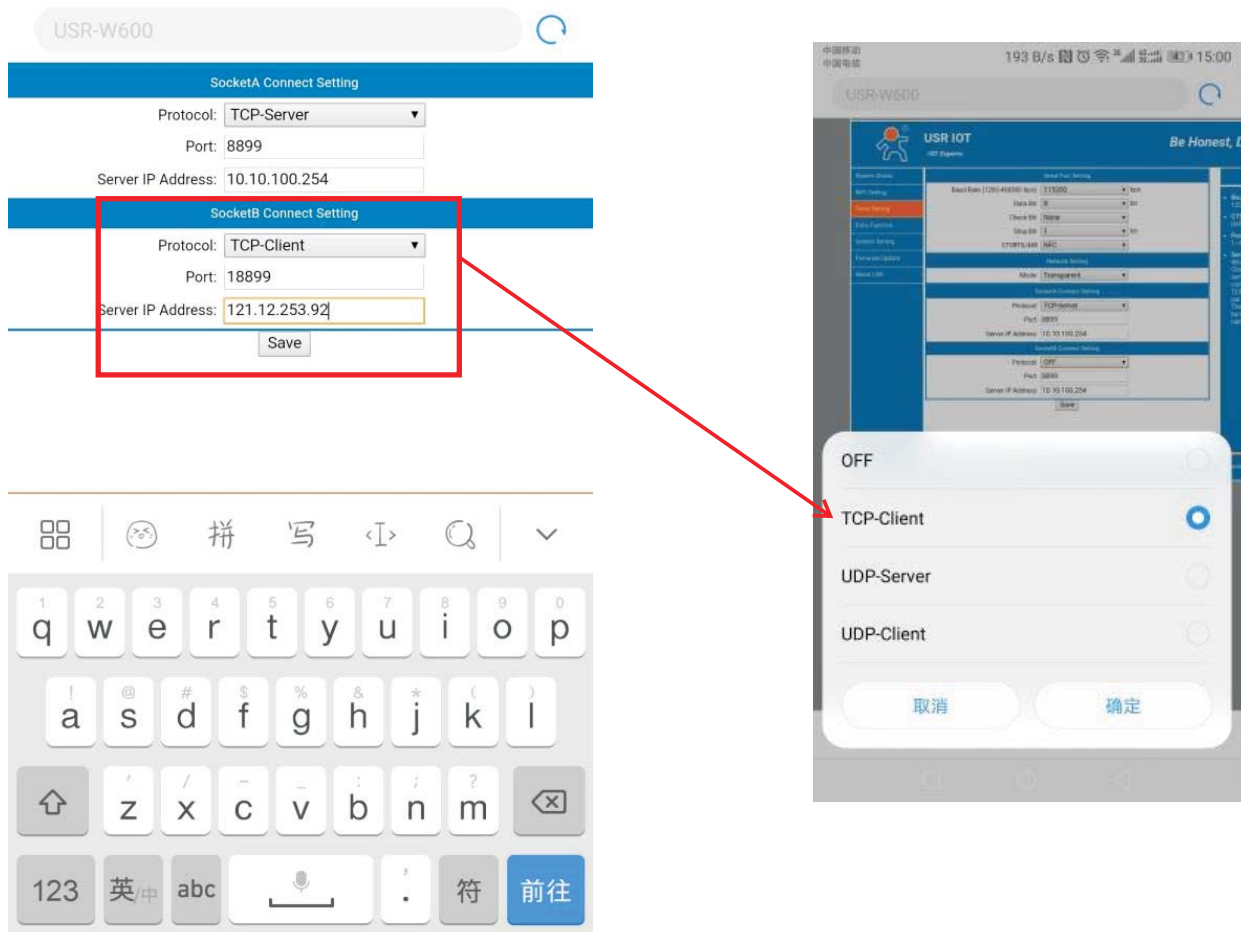

3. Usage

11. Choose “Restart”,to restart the WIFI equipment.

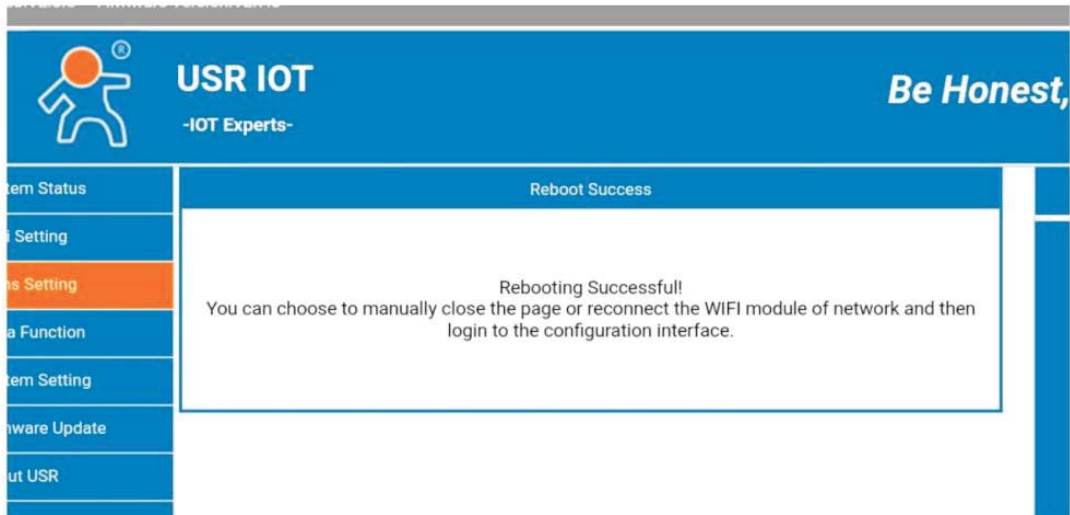
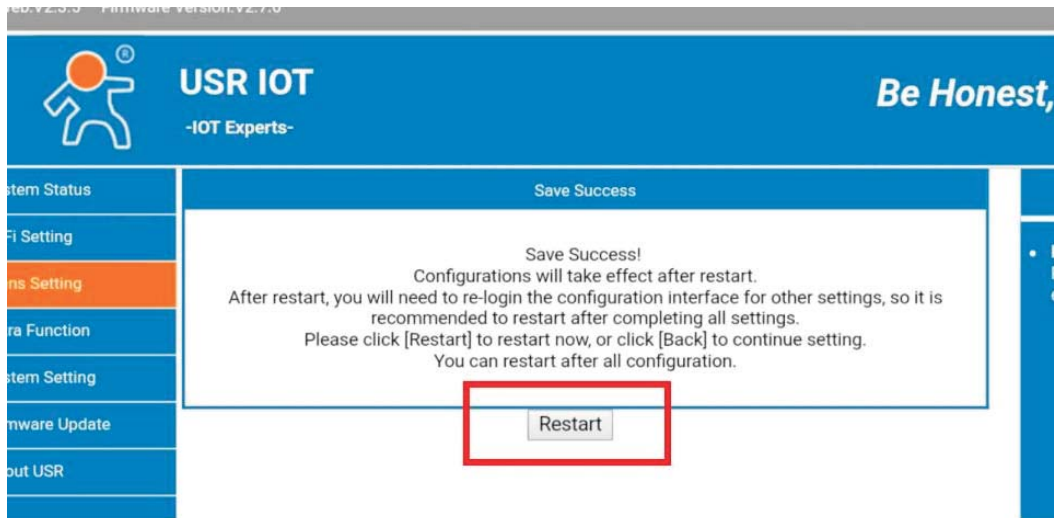

Record the MAC address as below.



3. Usage

After reset, power off and restart the operation panel;
Step 2: Configure manually

1. Log in APP, binding manually, as follows

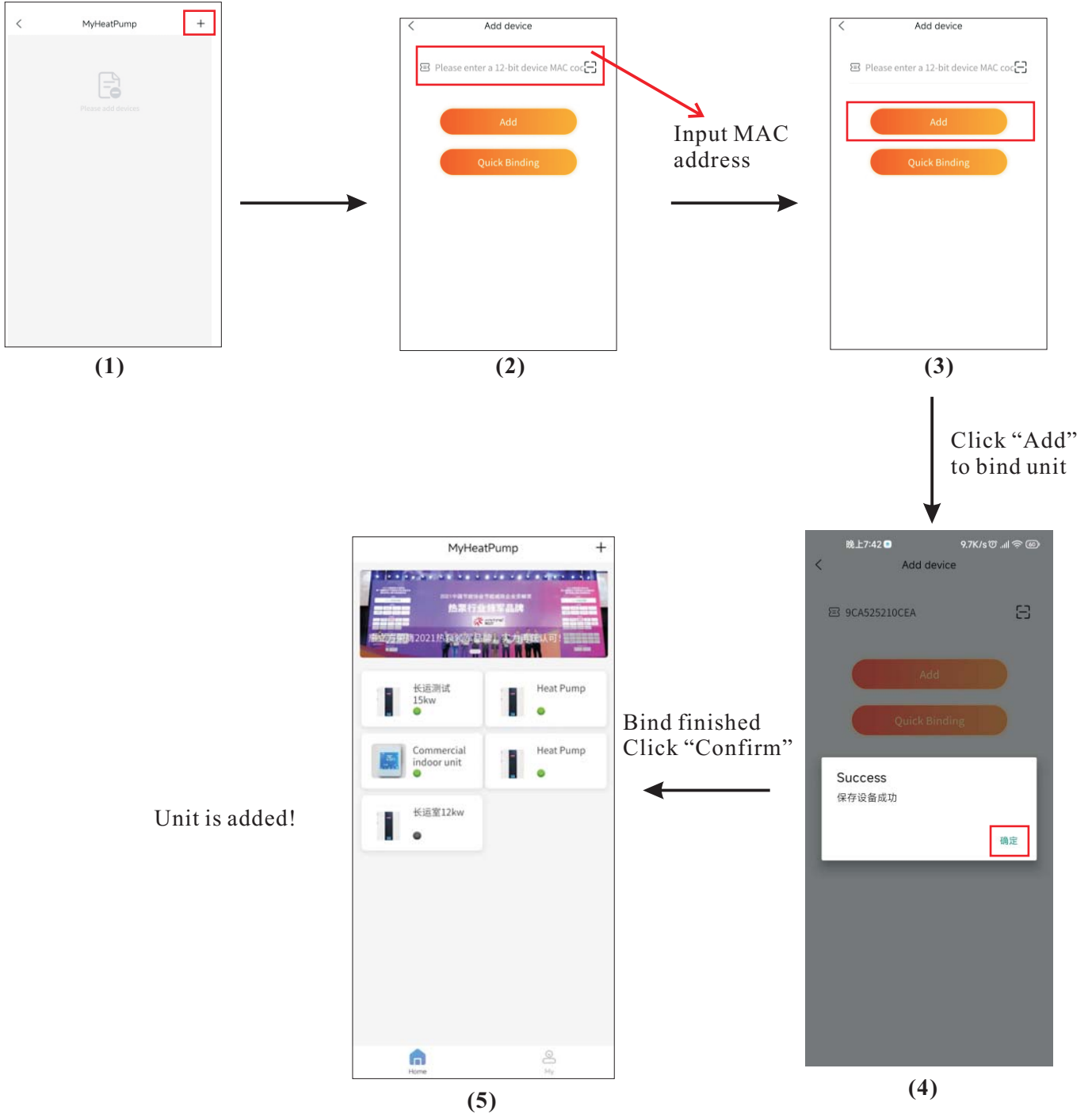

3. Usage

3.4 APP application

1. APP download

1.1 Login page <http://www.myheatpump.com>' as below

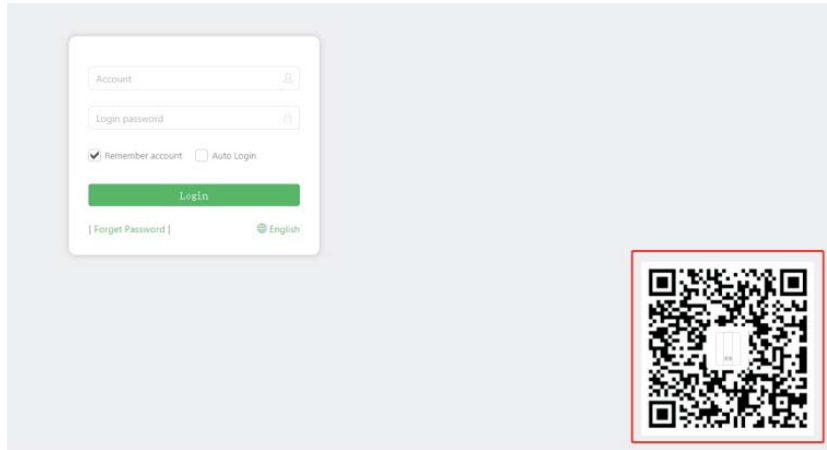

1.2 Scan the QR code with the mobile browser, and the download guide will pop up automatically.
Download and install APP according to the operating instructions.

2. APP login

In the app login interface, input the account number and password to login;

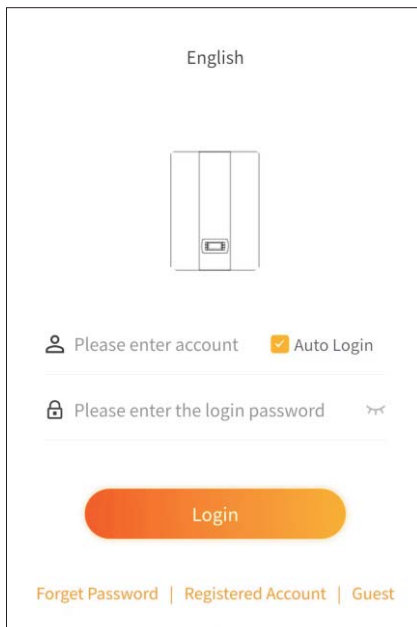

3. Usage

3.APP register

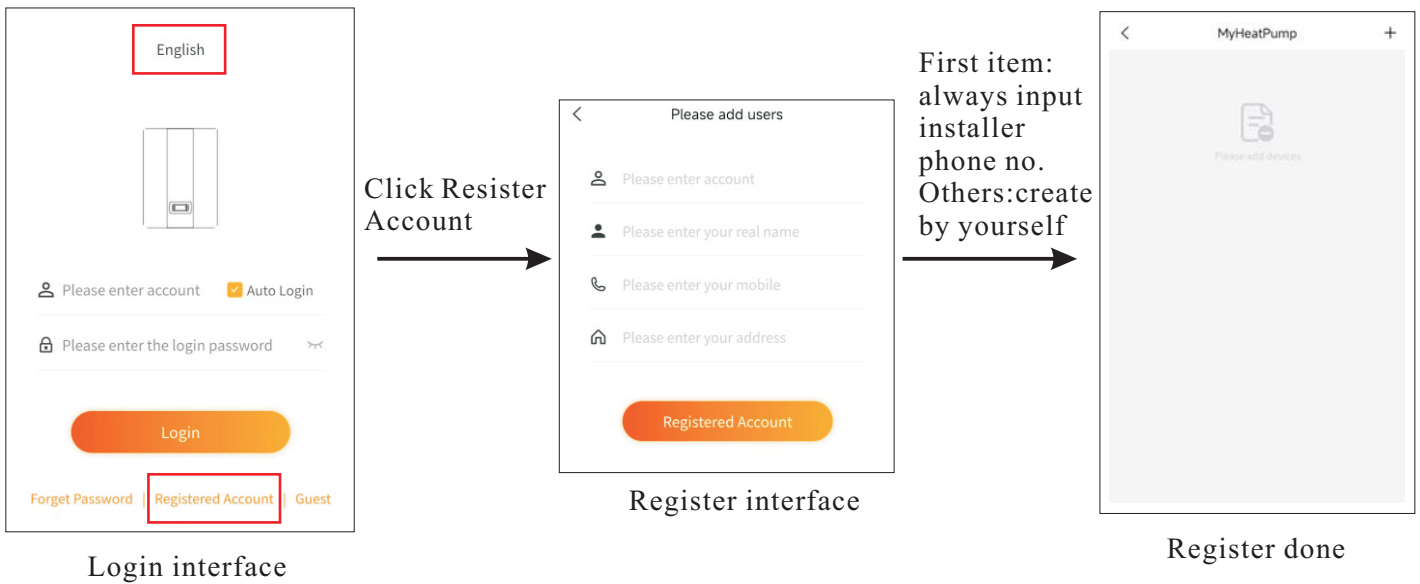

4.APP interface brief introduction



Main interface for account

1. Shows the unit bound by the current account.
2. Extra binding units can be added.
3. Click the unit icon to enter the unit operation interface.

3. Usage

Unit operation interface

1. Turn ON/OFF the unit
2. Display failure code
3. Display unit status
4. Display current setting water temp. and current water temp.
5. Edit setting water temp., mode and timing.

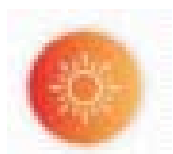

Switch to heating water temp. display and modify the heating set water temp.

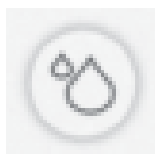

Switch to hot water temp. Display and modify the heating set water temp.



Switch working mode (heating, hot water, auto, and cooling).



Enter the parameter setting interface and timing setting.

3. Usage

3.5 Other Functions of the Wire Controller

1. Memory function:

When the heat pump is powered off suddenly, the operation panel will save parameter automatically;

2. Buzzer function:

Frequency of the buzzer sound: ring 1 second, pause 1 second;

1) When press one button, or two buttons for certain time, the buzzer will ring once;

2) When the unit has failures, there will be five buzzer rings for each failure;

3. Failures:

When the unit has failure, the single digits in the hour of clock area shows the letter of failure code, and the minute part shows the number of failure code. The value in temperature area shows normally. For example, the failure code F04 shows in the following picture:



(Normal)



(F04 failure code)

When multiple failures happen, each fault is shown for 5 seconds, and all faults are displayed in sequence continuously. After shown all faults in one cycle, clock is shown for 5 seconds, and then all faults are shown in next cycle;

3. Usage

Failure Codes			
Code	Failure	Controller Processing	Possible Reasons and Solutions
P01	Main line current protection	Unit stops for protection	If the current is too high or too low, the unit stops for protection. Unit recovers automatically after 5 minutes when it happens the first time. If the same failure happens for 3 consecutive times, unit stops until re-powered. If the unit is overloaded, check the heat exchange situation of the condensing side, whether the fan motor or water pump is working OK, whether the heat exchanger is blocked, whether the water temperature is too high, and whether the actual temperature difference between the inlet water and outlet water of the heat exchanger is normal (below 8°C).
P02	Compressor phase current protection	Unit stops for protection	Too high or too low compressor current protection, or unit is overloaded. Check heat exchanger situation of the condensing side to see whether the fan motor or water pump is working OK, whether the heat exchanger is blocked, whether the water temperature is too high and the actual temperature difference between the water inlet and outlet of the heat exchanger is normal (below 8°C).
P03	IPM module protection	Unit stops for protection	The drive board has failure. Check whether cables are loose. If the cables are connected well, replace drive board. If failure still exists, replace compressor.
P04	Compressor oil return protection	Outdoor controller protection	If the unit operates in low-frequency F3 for more than 20 minutes, it causes poor oil return, which is normal protection and needs no treatment.
P05	High pressure switch protection	Unit stops for protection	If the system pressure exceeds the set value of the pressure switch, unit stops for protection. Unit recovers automatically after 5 minutes when it happens the first time. If the same failure happens for 3 consecutive times, unit stops until re-powered. Check the heat exchange situation of the condensing side, whether the fan motor or water pump is working OK, whether the heat exchanger is blocked, whether the water temperature is too high, and whether the actual temperature difference between the inlet water and outlet water of the heat exchanger is normal (below 8°C).
P06	High pressure protection	Unit stops for protection	If the system pressure reaches the pressure protection value, check whether the water temperature is set too high, the water flow is too small, the expansion valve control is abnormal, the outside ventilation is poor while cooling, or the ambient temperature is too high. If it happens three times in half an hour, the failure code will turn into F12.
P07	Compressor preheating protection	Outdoor controller protection	When the system is powered on below -5°C, this is a normal protection and doesn't need any treatment, and the protection will be cleared out after 30 minutes.
P08	Too high compressor discharge temp. protection	Unit stops for protection	The discharge temperature is too high, the water temperature is set too high when ambient temperature is low, the water flow is too small, or the unit lacks refrigerant.

3. Usage

Failure Codes			
Code	Failure	Controller Processing	Possible Reasons and Solutions
P09	Outdoor evaporator coil temp. sensor protection	Unit stops for protection	There is too high outdoor evaporator coil temperature at cooling or the air volume is too small. Check whether the air outlet is blocked. Too low Indoor coil temperature protection while cooling, check the water flow. Refer to P05, if the same failure happens three times in half an hour, the unit stops until re-powered.
P10	Too high/low input voltage protection	Unit stops for protection	Check whether unit input voltage is too high ($\geq 270V$) or too low ($\leq 140V$)
P11	Compressor shut down due to too high/low ambient temperature	Unit stops for protection	The ambient temperature exceeds the allowable working range The working range of cooling is 11~55°C; The working range of heating is-30~45°C.
P14	Anti-freezing protection-stage 1	The circulation pump stops for 6 minutes and then work for 1 minute.	System security protection.
P15	Anti-freezing protection-stage 2	If the ambient temperature and the water outlet temperature are lower than the set starting temperature, the heat pump starts working. If the water outlet temperature is higher than the set target temperature or if the ambient temperature is higher than the set ambient temperature for closing activation, the stage-2 anti-freezing protection exits.	System security protection.
P18	Low pressure protection	Unit stops for protection	The low pressure is lower than protection value, the water flow is too small, the expansion valve control is abnormal, the outside ventilation is poor during cooling, or the ambient temperature is too high. If the same failure happened 3 times in half an hour, the failure code turns into F11;
F01	Outdoor ambient temp. sensor failure	Unit stops for protection	Outdoor ambient temp. sensor is disconnected or short-circuited. Change the Ta sensor. When this failure happens only when the unit is working, the ambient temp. sensor and the coil temp. sensor may be misplaced.
F02	Outdoor coil temp. sensor failure	Unit stops for protection	Outdoor coil temp. sensor is disconnected or short-circuited. Replace the Tp sensor.
F03	Compressor discharge temp. sensor failure	Unit stops for protection	Compressor discharge temp. sensor is disconnected or short-circuited. Replace the Td sensor.

3. Usage

Failure Codes			
Code	Failure	Controller Processing	Possible Reasons and Solutions
F04	Compressor suction temp. sensor failure	Unit stops for protection	Compressor suction temp. sensor is disconnected or short-circuited. Replace the Ts sensor.
F05	Evaporating pressure sensor failure	Unit stops for protection	Evaporating pressure sensor is disconnected or short-circuited or there is component fault. Replace it if necessary. or EEPROM setting is wrong.
F06	Condensing pressure sensor failure	Unit stops for protection	Condenser pressure sensor is disconnected or short-circuited. Replace it if necessary. or EEPROM setting is wrong.
F07	High pressure switch failure	Unit stops for protection	1. If high pressure switch is in open position when unit is in standby statue, or 2 minutes after compressor stops, unit gives this failure.; 2. P05 pressure switch protection has happened for three times, and then it becomes F07. It only recovers until re-powered. Check whether high or low pressure switch is broken or not well connected. Whether the water flow is too small, whether water outlet temp. Sensor is loose or damaged, whether fan motor or EEV works abnormal; whether unit works in cooling when ambient temp. is too high.
F08	Low pressure switch failure	Unit stops for protection	1. If low pressure switch is in open position when unit is in standby statue, or 2 minutes after compressor stops, unit gives this failure.; 2. P13 pressure switch protection has happened for three times, and then it becomes F08. It only recovers until re-powered. Check whether low pressure reaches the protection value or low pressure switch is broken. Check whether water flow is too small; whether EEV works abnormal; whether the ventilation is good at cooling; whether fan motor works abnormal in low ambient temp.; whether the unit lacks of refrigerant.
F09	DC fan motor A failure	Reduce speed for protection (double fan system) or compressor shutdown (single fan system). For double fan system, if two fans fail at the same time, the compressor stops.	DC fan motor can't reach the required speed or no feedback signal. Please check whether the PCB or fan motor is broken. Replace it if necessary; or EEPROM is set to AC motor by mistake .
F11	System evaporating pressure failure	Unit stops for protection	If too low pressure protection detected by evaporating pressure sensor happened 3 times in half an hour, P18 becomes F11. Check whether system has not enough refrigerant or leakage inside, more likely it has no enough refrigerant that caused this abnormal evaporating pressure; whether fan motor and water pump is working OK; whether evaporator is blocked; whether EEV whether EEV works normally; whether water temperature too low, and whether water inlet&outlet temperature has too big difference in cooling(should no bigger than 8°C).

3. Usage

Failure Codes			
Code	Failure	Controller Processing	Possible Reasons and Solutions
F12	System condensing pressure too high	Unit stops for protection	If system too high pressure protection detected by condensing pressure sensor happened 3 times in half an hour, it gives this failure code and unit can't be restarted until re-powered. Check whether water flow rate is not enough ,more likely it has no enough water flow rate that caused system build up too high pressure; whether fan motor and water pump is working OK; whether condenser is blocked; whether EEV works normally; whether water temperature too high, and whether water inlet&outlet temperature has too big difference (should no bigger than 8°C).
F14	Hot water temp. sensor failure	Hot water mode stops working	Hot water mode stops working. Replace the Tw sensor.
F16	Water outlet temp. sensor failure	Unit shutdown for protection	Tuo The water outlet temp. sensor is disconnected or short-circuited. Replace the Tuo sensor.
F17	water inlet temp. sensor failure	Unit shutdown for protection	The water inlet temp. Sensor Tui is disconnected or short-circuited. Replace the Tui sensor.
F18	Indoor coil temp. sensor failure	Unit shutdown for protection	Tup Indoor coil temp.sensor Tup is disconnected or short-circuited. Replace the Tup sensor.
F27	Indoor EEPROM failure	Treatment is not needed but the unit runs with reset values	Reset the EEPROM setting or replace the indoor PCB
E01	Communication failure between indoor main control PCB and outdoor main control PCB	Unit stops for protection	The RS485 communication cable AB is disconnected or wrongly connected, or the PCB is damage. Check and replace them.
E02	Communication failure between outdoor main PCB and compressor driver board	Unit stops for protection	The communication cable is disconnected or the driver board is damaged. Check and replace them.
E03	Compressor phase current failure (open/short circuit)	Unit stops for protection	Check whether the power cable to compressor is broken or short-circuit or not well connected. Replace the cable. Whether the unit lack of refrigerant, refill it. If cable and refrigerant are OK, replace the driver PCB.
E04	Compressor phase current overload (too high current)	Unit stops for protection	Check whether the power cable to compressor is broken or short-circuit or not well connected. Replace the cable. Whether the unit lack of refrigerant, refill it. If cable and refrigerant are OK, replace the driver PCB.
E05	Compressor driver board failure	Unit stops for protection	The driver board is damaged or the cable between driver board and compressor is loose. Check and replace them.
E06	Compressor driver board over high/low voltage failure	Unit stops for protection	Check whether input voltage is too high ($\geq 270V$) or too low ($\leq 140V$) .

3. Usage

Failure Codes			
Code	Failure	Controller Processing	Possible Reasons and Solutions
E07	AC current failure	Unit stops for protection	1. Check whether the PCB is damaged. Use an ammeter to measure the current of the outdoor unit, and compare it with the current value in the system parameters on the display screen. If the two values have large difference, it indicates that the PCB is damaged and needs to be replaced. 2. If the measured current is too small, please check whether unit lacks of refrigerant; 3. The L line of the normally open relay of the power board is connected to the module board without passing through the transformer, resulting in current 0A;
E08	EEPROM failure	Unit stops for protection	Re-program the EEPROM, because the default EEPROM may not be suitable for this model configuration;
S01	Anti-freezing protection in cooling	Unit stops	1. The water temperature is too low and the water flow is too small during cooling. Check whether the water temperature setting is too low, whether the water system is normal, whether the filter is blocked, and whether the water pump is running normally. 2. The amount of refrigerant is too small, check the low pressure to see whether it is necessary to add refrigerant. 3. When the ambient temperature is lower than 15°C, cooling is started. This fault may occur. 4. If it has occurred three times within 30 minutes, and it cannot restart unless re-powered.
S02	Water flow switch protection	Restart after three minutes of shutdown	1. If the water flow is lower than 50% of the rated flow, check whether the water circuit is normal, whether the filter is blocked, and whether the water pump is running normally. 2. S02 turns into S10 when it happens three times within 30minutes.
S03	Water flow switch failure	When the water pump is not working, the water flow switch is open and it will be restored;	When the unit is in shutdown or standby state, if water flow switch is closed (ON), check whether the water flow switch is damaged or stuck.
S04	Communication failure between operation panel and indoor PCB	Unit stops	1. check whether the communication cable is connected correctly; 2. Check whether the communication cable is too long (more than 30 meters) and whether there is an interference source near the unit. If so, add an anti-interference magnetic ring to the communication cable; 3. The operation panel or the indoor PCB is broken. Replace it with a new one.
S06	Too low water outlet temp. protection in cooling	Unit stops	When water outlet temperature is too low during cooling, check whether the outlet water (Tuo) temperature sensor is connected well, whether the water temperature setting is too low, and whether the water flow is too small.
S09	Defrosting failure	Unit stops	When the water outlet temperature $\leq 5^{\circ}\text{C}$, and if the defrosting fails for three consecutive times, this fault will be reported continuously and just can be cleared out after re-power.

3. Usage

Failure Codes			
Code	Failure	Controller Processing	Possible Reasons and Solutions
S10	water flow switch failure	The heat pump stops working and cannot be restored unless powered off	If the water flow is lower than 50% of the rated flow, check whether the water circuit is normal, whether the filter is blocked, and whether the water pump is working normally. 2. Whether the water flow switch is stuck; 3. S02 turns into S10 after the failure happened three times within 30 minutes.
S11	Anti-freezing protection failure in cooling	The heat pump stops working and cannot be restored unless powered off	If "indoor coil anti-freezing protection in cooling mode" happens over 3 times in certain period of time, it gives this failure code and unit stops until repower. 1. Check whether set temperature for cooling is too low; whether system has too small water flow rate; check water system especially the filter. 2. Check whether system has not enough refrigerant inside by measuring the evaporating pressure. 3. Check whether ambient temperature is lower than 15°C.

3. Usage

3.6 Other functions

1. Remote switch

1) Function description: When the heat pump is in cooling and heating mode, the system enters the working state only when the remote switch is detected closed (ON). When the remote switch is detected OFF, the system immediately stops for protection, and there is no failure code. The terminal equipment can use this switch to control ON/OFF of the heat pump.

2) Function port: PCB TS1 port---ES terminal.

2. 485 communication

Function description:

The unit has a standard 485 communication protocol, which can cooperate with external controllers for more interactive control applications.

3. Auxiliary Electric Heating (AS)

1) Function description: When the ambient temperature is low and the heat pump heats up the temperature slowly, it means that the heating capacity of the heat pump is not enough. In order to make the house more comfortable, auxiliary electric heating can be turned on.

2) Precautions: Before turning on the auxiliary electric heating, make sure the water tank are filled with water to avoid dry burning.

Note: There is no auxiliary electric heater inside this heat pump, but there is a terminal AS to connect to external electric heater.

4. Three-way valve

1) Function description: It is used for switching between hot water and heating/cooling in the water system. The default switching method is as follows:

When there is a demand for heating or cooling, the DV port gives out 220V signal. When there is no demand for heating or cooling, the DV port gives out 0V signal; that is, when the water system has no demand, it switches to the hot water mode by default;

Note: There is no three-way valve inside heat pump, but there are terminals (Na, DV, La) for the user to connect an external three-way valve.

5. Circulating water pump

1) Function description: When unit is in standby, the circulating water pump works with 6-minutes off and the 1 minute on;

2) The circulating water pump is turned on 30S ahead of the heat pump or auxiliary electric heater starts; when the heat pump frequency is 0 and the auxiliary electric heating is not working, it will be turned off in 30 seconds after heat pump stops, and then it will be turned ON for one minute after stops for N minutes.

N can be set from 1 to 15 minutes.

3. Usage

6. Low noise mode

1) Function description: When it is necessary to reduce the operating noise of the heat pump, you can set the low noise mode to reduce the speed of the fan motor and the compressor at the same time.

2) Change the value of the user parameter list [6] from "0" to "1", heat pump enters the low-noise mode and works with low noise.

When the low-noise mode is turned on, the maximum operating frequency of the heat pump compressor can only reach F7 (there are ten gears, from F1 to F10, the higher the gear, the higher the frequency of the compressor), and the maximum speed of the fan motor can only reach the set speed of the low-noise mode (for example: the set speed of the low-noise mode is 580r/min, when the low-noise mode is turned on, the maximum speed of the fan motor can only reach 580r/min).

4. Maintenance

4.1 Attention

- 1) The user mustn't change the structure or wiring inside the unit.
- 2) The service and maintenance should be performed by qualified and well-trained technician. When the unit fails to run, please cut off power supply immediately.
- 3) The smart control system can automatically analyze various protection problems during daily use, and display the failure code on the controller. The unit may recover by itself. Under normal operation, the piping inside the unit don't need any maintenance.
- 4) In normal ambient conditions, the user only needs to clean the surface of the outdoor heat exchanger per month or quarter of a year.
- 5) If the unit runs in a dirty or oily environment, please clean the outdoor heat exchanger by professionals, using specified detergent, to ensure the performance and efficiency of the unit.
- 6) Please pay attention to the ambient environment, to check if the unit is installed firmly, or whether the air inlet and outlet of the outdoor unit is blocked.
- 7) Unless the water pump is damaged, no special service or maintenance should be taken to the water system inside the unit. It's recommended to clean water filter regularly or change it when it's very dirty or blocked.
- 8) If the unit will not be used in winter for a long time, please drain all the water inside the system, to prevent the water pipes from damage due to freezing.

4.2 Cleaning of water filter

The water filter should be cleaned according to the manual of water filter, to ensure the water flow of the water system. It is recommended that it be cleaned once in the first month, and then, once half a year.

4.3 Cleaning of plate heat exchanger

Thanks to the normally very high degree of turbulence in the heat exchanger, there is a self-cleaning effect in the channels. However, in some applications the fouling tendency can be very high, e.g. when using extremely hard water at high temperatures. In such cases it is always possible to clean the exchanger by circulating a cleaning liquid (CIP-Cleaning In Place). Use a tank with weak acid, 5% phosphoric acid or, if the exchanger is frequently cleaned, 5% oxalic acid. Pump the cleaning liquid through the exchanger. This work should be done by qualified person. For further information, please contact your supplier.

4. Maintenance

4.4 Condenser coil

The condenser coils do not require any special maintenance, except when they are clogged by paper or any other foreign objects. Cleaning is by washing with detergent and water at low pressure, and then rinsing with clean water:

- 1) Before cleaning, make sure the unit is off.
- 2) Inner of the unit must be cleaned by qualified person.
- 3) Do not use gasoline, benzene, detergent etc. to clean the unit. And do not spray with insecticide. Otherwise the unit may be damaged. The cleanser special made for air conditioner cleaning is recommended.
- 4) Spray air conditioner cleanser into the coils. Let the cleaner sit for 5-8 minutes.
- 5) Then, spray the coil with clean water.
- 6) An old hairbrush works well for brushing surface dirt and lint off the fins. Brush in the same direction as the slots between the fins so the bristles go between the fins.
- 7) After cleaning, use a soft and dry cloth to clean the unit.

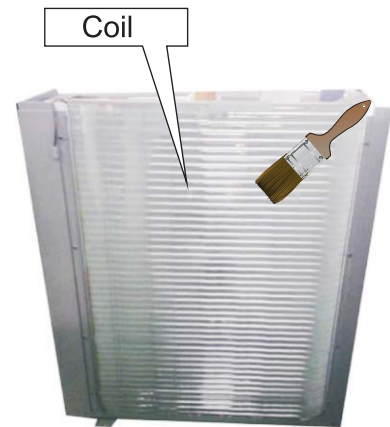

4. Maintenance

4.5 Service Of Monoblock Unit

4.5.1 Service Of Water pump

A. Cut unit power supply, dismantle the service panel, and disconnect the quick connector of pump cable.

B. Cut unit water supply, drain the system, and dismantle the pump with wrench.

C. Install the new pump back, connect the cable with quick connector.

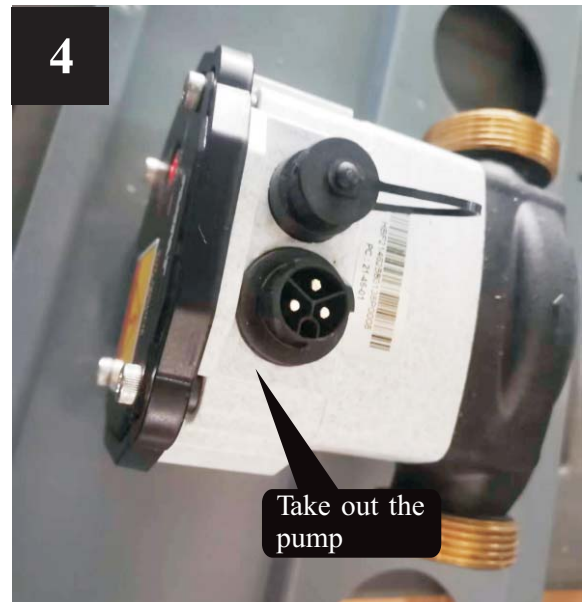
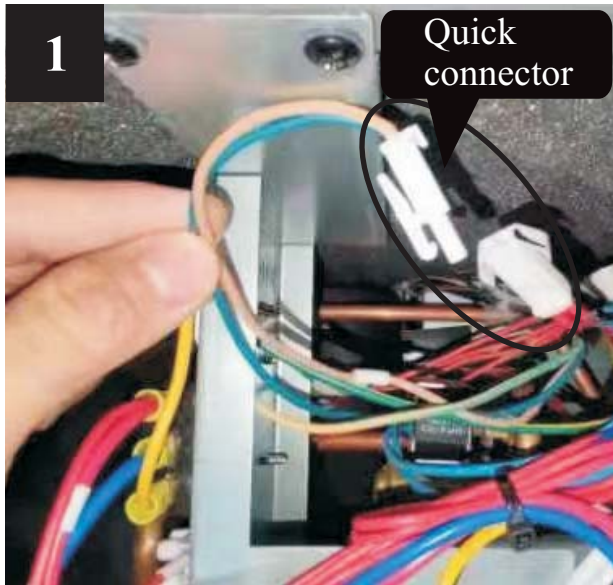

4. Maintenance

4.5.2 Maintenance of controller

- 1) Cut off the power supply, take off the top cover of the unit.
- 2) Take off the electric box cover.
- 3) Do necessary maintenance work to the controller of outdoor unit .

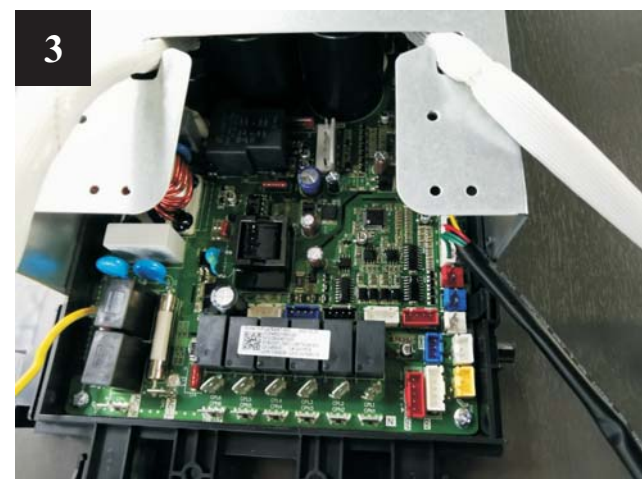
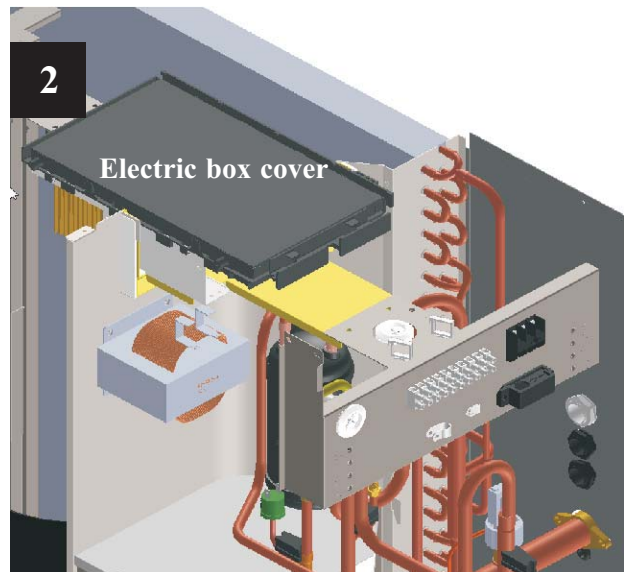
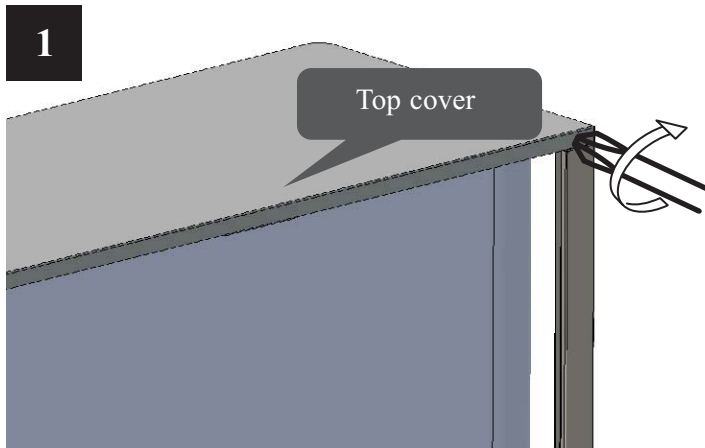

4. Maintenance

4.5.3 Service of fan blade and fan motor

- 1) Cut unit power supply, dismantle the top cover, then the front panel.
- 2) Disconnect the quick connector of power cable for the fan motor.
- 3) Use a wrench to loosen the nut for fan blade.
- 4) Take off the screws of fan motor.
- 5) Put the repaired or new fan motor back and connect all cables back.

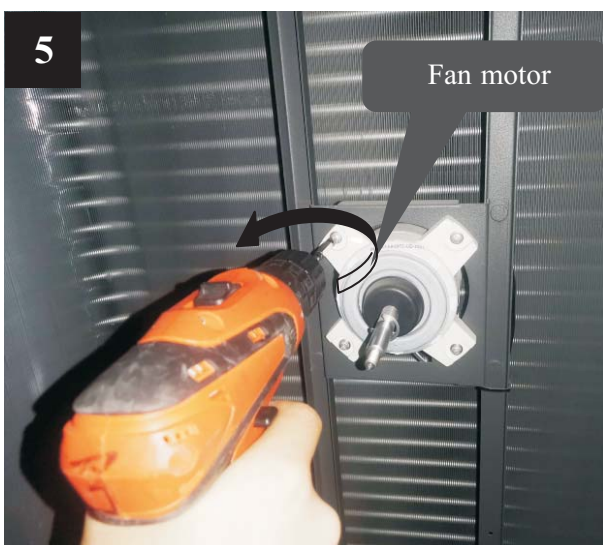
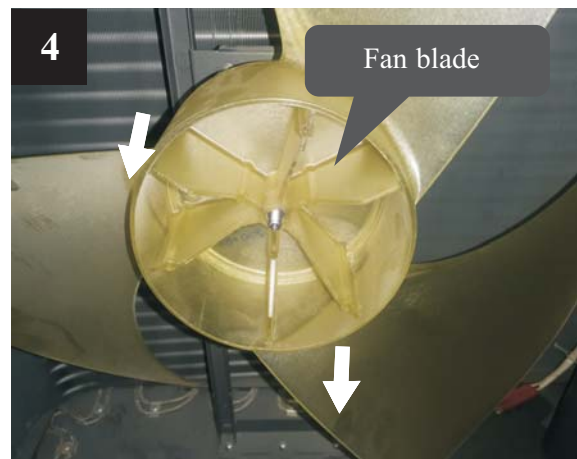

4. Maintenance

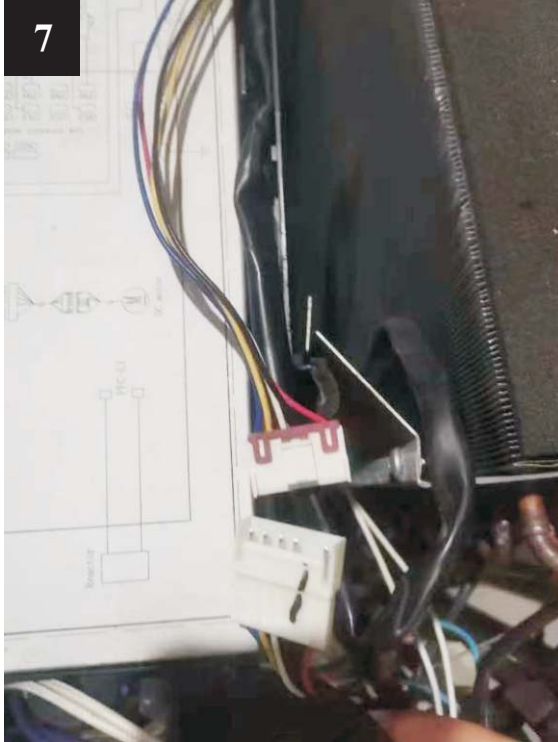

4. Maintenance

4.5.4 Replacement of bottom plate heater

- 1) Cut off the power supply, follows 4.5.3 to take out the fan blade.
- 2) Take off the fixture of bottom plate heater(see picture 1).
- 3) Disconnect the quick connector for bottom plate heater and take the heater out (see picture 2).
- 4) Put a new bottom plate heater back, and connect it to the quick connector(see picture 3).

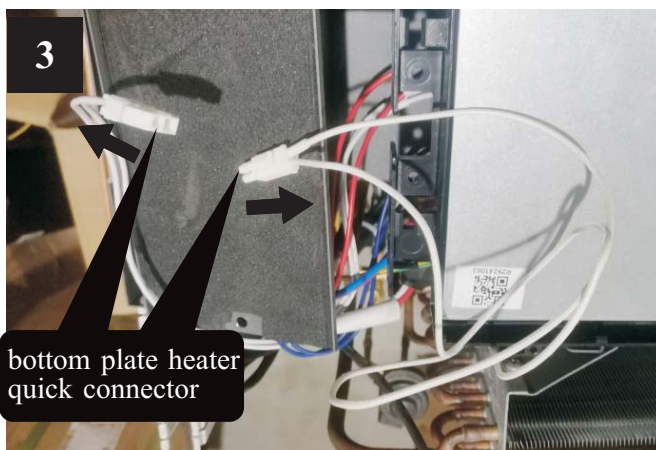
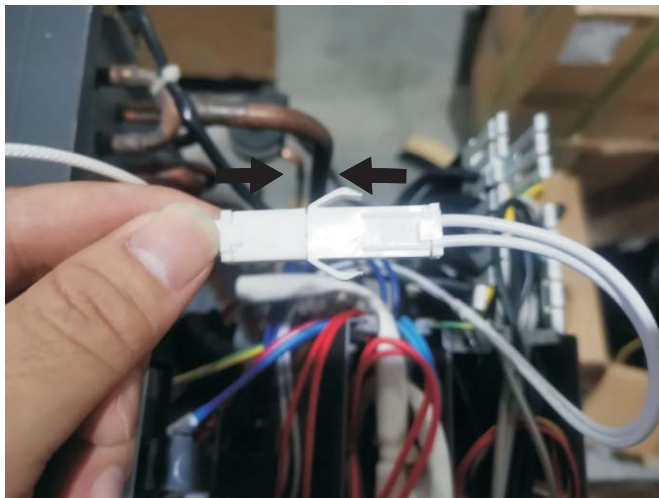
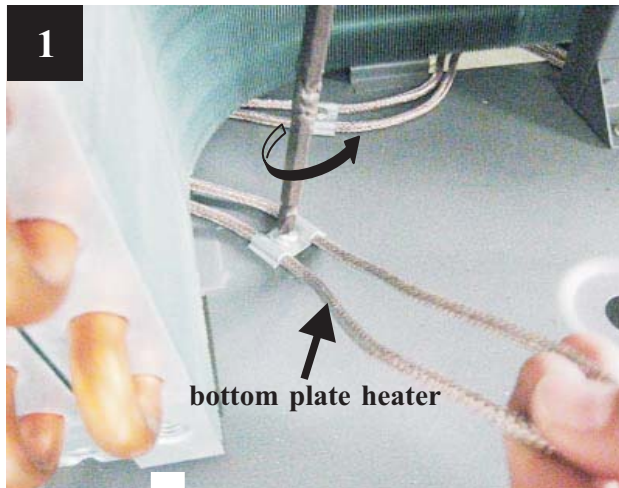

4. Maintenance

4.6 Trouble shooting

Failure	Cause	Solution
Unit can't start up	1. No power supply	1. Check the power supply
	2. Fuse is broken or circuit breaker is disconnected	2. Check if it's open circuit or if the unit is earthed. Then change a fuse and reset the breaker, check if the circuit is stable or the connection is well.
	3. Some kind of protection works	3. Check which protection is working, and clear the protection, then restart the unit.
	4. Wiring is loose	4. Check the wire connection and tighten the screws on the terminal
	5. compressor fails	5. Change a compressor
Fan fails to run	1. Fan motor wire loose	1. Check the wire connections.
	2. fan motor failure	2. Change fan motor.
Low heating performance	1. The coil fins are very dirty	1. Clean the evaporator coil
	2. Air inlet is blocked	2. Remove any object that blocks the air circulation of the unit.
	3. Insufficient of refrigerant	3. Inspect the unit for leakage and fix it if any. Discharge all refrigerant and charge the unit again with correct amount.
Too high noise from the water pump, or no water flow when the water pump is running	1. Lacking of water in water system	1. Check the water filling device. Fill the system with enough water.
	2. Air exists in water system	2. Purging the air out.
	3. Valves in water system are not completely opened	3. Check all the valves to ensure they are fully opened.
	4. Water filter is dirty or blocked	4. Clean the water filter
Too high compressor discharge pressure	1. Too much refrigerant	1. Discharge all refrigerant and charge the unit again with right amount.
	2. Air exists in refrigeration system	2. Discharge all refrigerant and charge the unit again with right amount.
	3. Inadequate water flow	3. Check the water flow of the system. Use a bigger pump to increase the water flow if necessary.
	4. Too high water temperature	4. Check the value of the water temperature sensor, to ensure it works properly.
Too low suction pressure	1. Drier filter is blocked	1. Change a new one
	2. Electronic expansion valve is not opened	2. Repair or change a new one
	3. Leakage of refrigerant	3. Inspect the unit for leakage and fix it if any. Discharge all refrigerant and charge the unit again with right amount.
Unit can not defrost properly	1. Coil temperature sensor failure	1. Check the position and value of the coil temperature sensor. Replace it if necessary.
	2. Air inlet/outlet is blocked	2. Remove any object that blocks the air circulation of the unit. Clean the evaporator coil occasionally.

4. Maintenance

The following phenomenon may not be problems of unit itself.
Please contact with a professional maintenance staff for help.

Number	Failure	Solution
1	The unit is not running	When the unit restarts, the compressor will start 3 minutes later (self-protection of compressor), please check if the circuit breaker is disconnected, and if there is normal power supply for the wire controller.
2	Low capacity	Check if the air inlet or outlet is blocked in outdoor unit; unit; check if the setting temperature is too high in cooling mode, or too low in heating mode.

5. Attached drawing

5.1 Outlines and dimensions

Monoblock — FSH HP06V1FXC

Pipe Connection: 1"

Unit: mm

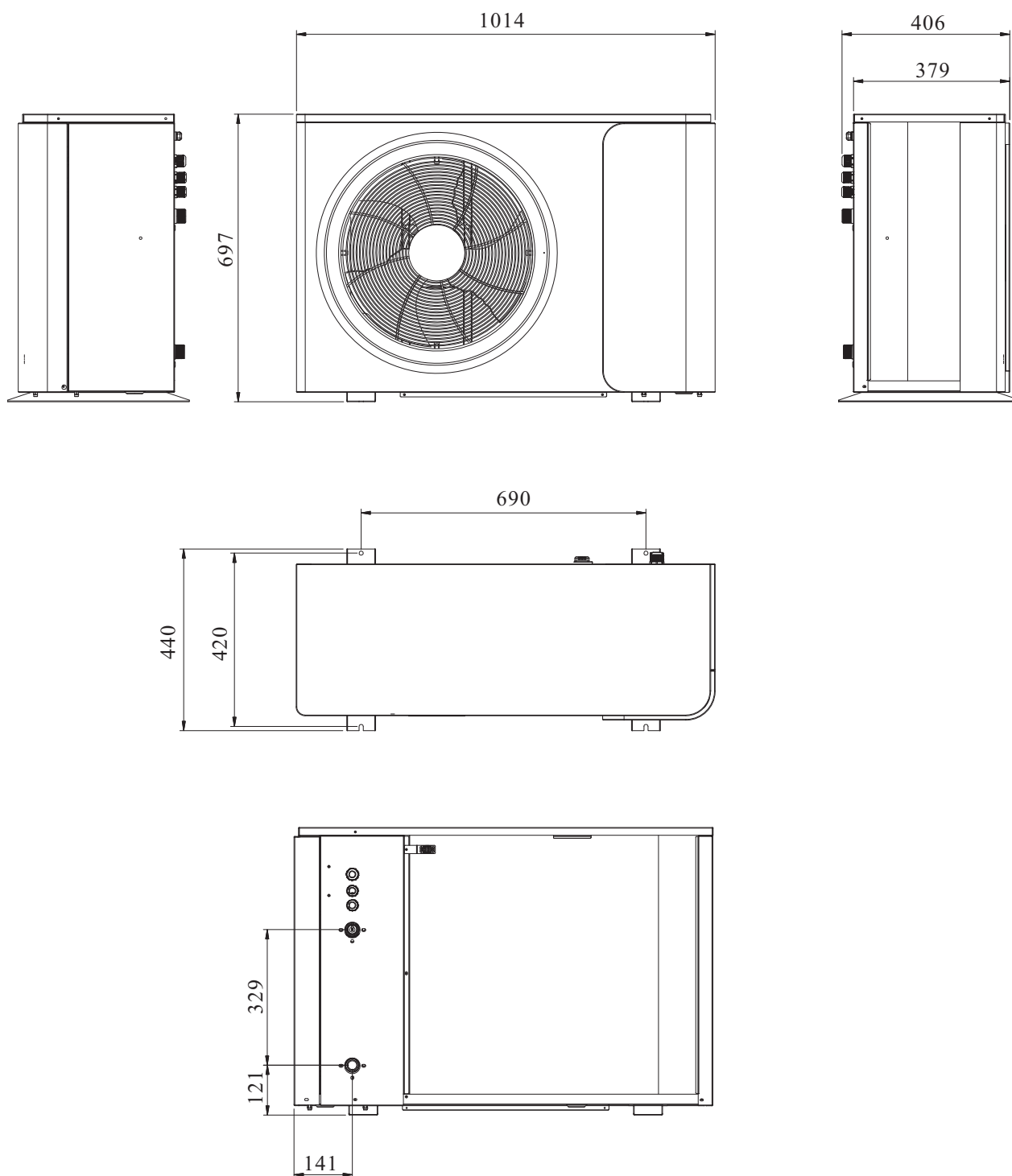

5. Attached drawing

Monoblock — FSH HP 09V1FXC / FSH HP 12V1FXC

Pipe Connection: 1"

Unit: mm

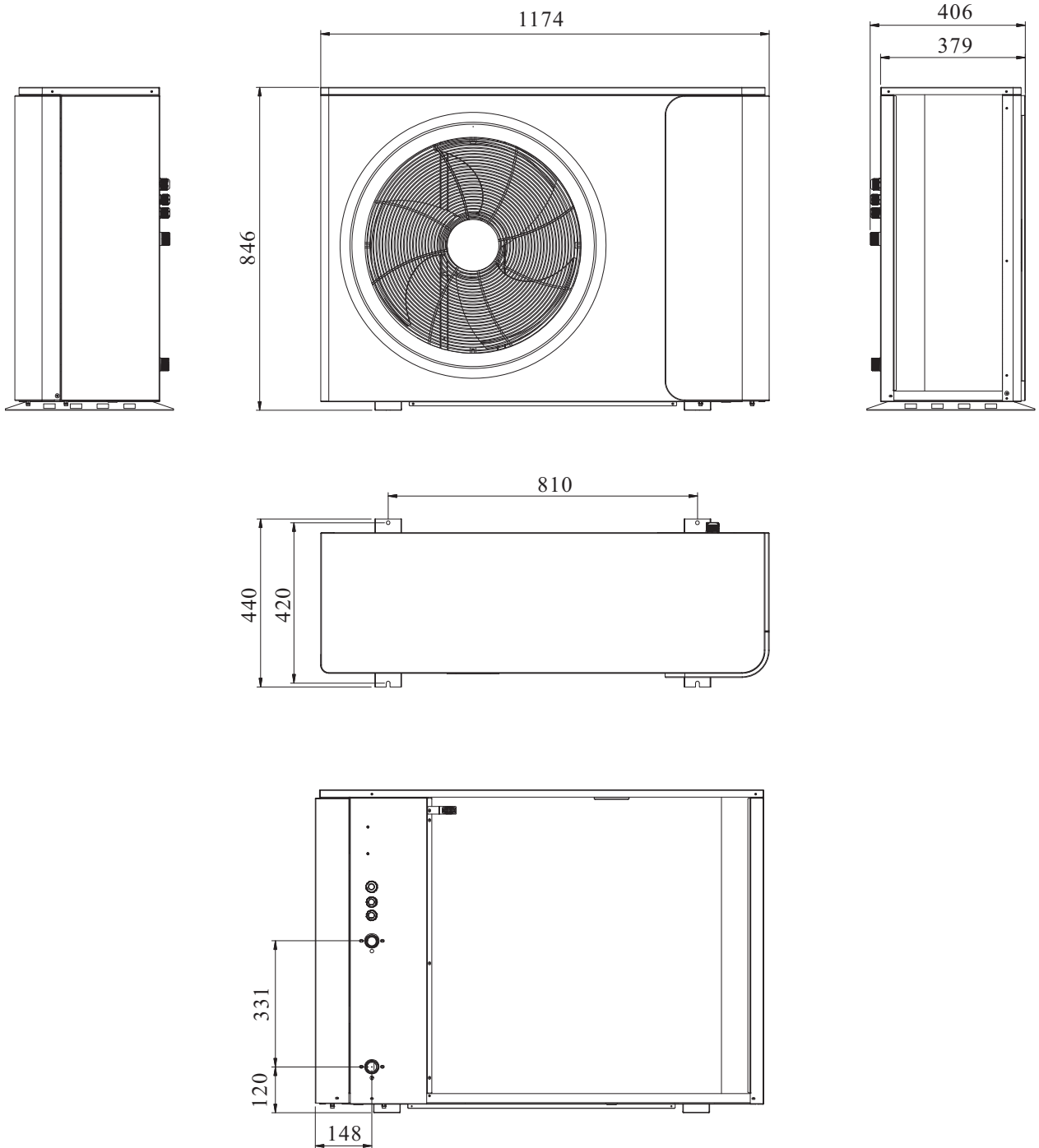

5. Attached drawing

5.2 Exploded View

Monoblock — FSH HP 06V1FXC

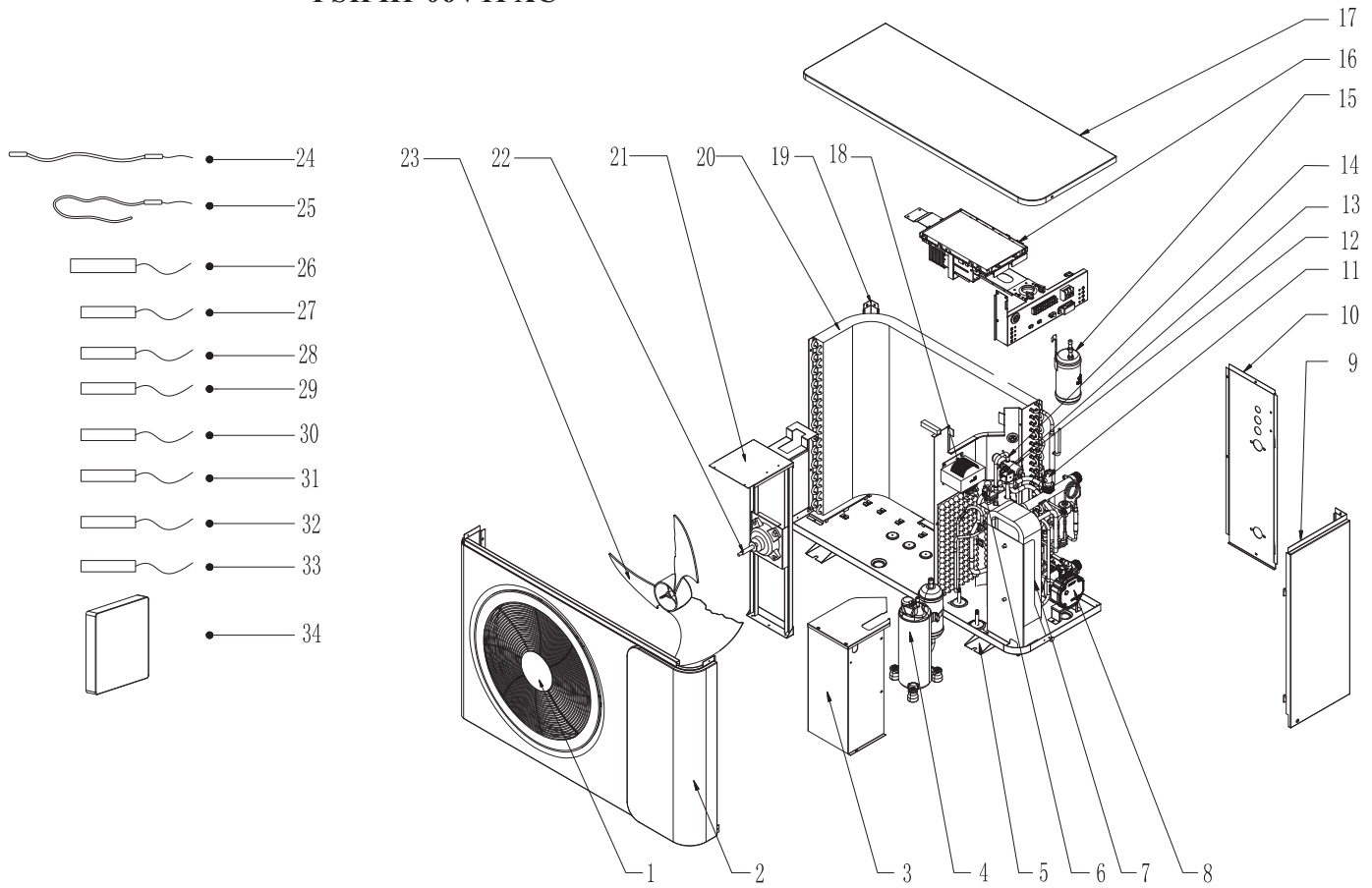

NO	Name	NO	Name
1	Fan Grill	18	Transducer
2	Front Panel	19	Back Column
3	Compressor Houseing	20	Evaporator
4	Compressor	21	Fan Motor Bracket
5	Bottom Plate	22	Fan Motor
6	High Pressure Switch	23	Fan Blade
7	Plate Heat Exchanger	24	Bottom Plate Heater
8	Water Pump	25	Comprssor Crankcase Heater
9	Service Panel	26	Comprssor Discharge Temp. Sensor
10	Back Panel	27	Compressor Suction Temp. Sensor
11	Flow Switch	28	Outdoor Coil Temp. Sensor
12	Low Pressure Sensor	29	Ambient Temp. Sensor
13	4-way Valve Coil	30	Water Inlet Temp. Sensor
14	4-way Valve	31	Water Outlet Temp. Sensor
15	Accumulator	32	DHW Temp. Sensor Tw
16	Control PCB	33	Indoor Coil Temp. Sensor
17	Top Panel	34	Operation Panel

5. Attached drawing

5.2 Exploded View

Monoblock — FSH HP 09V1FXC
FSH HP 12V1FXC

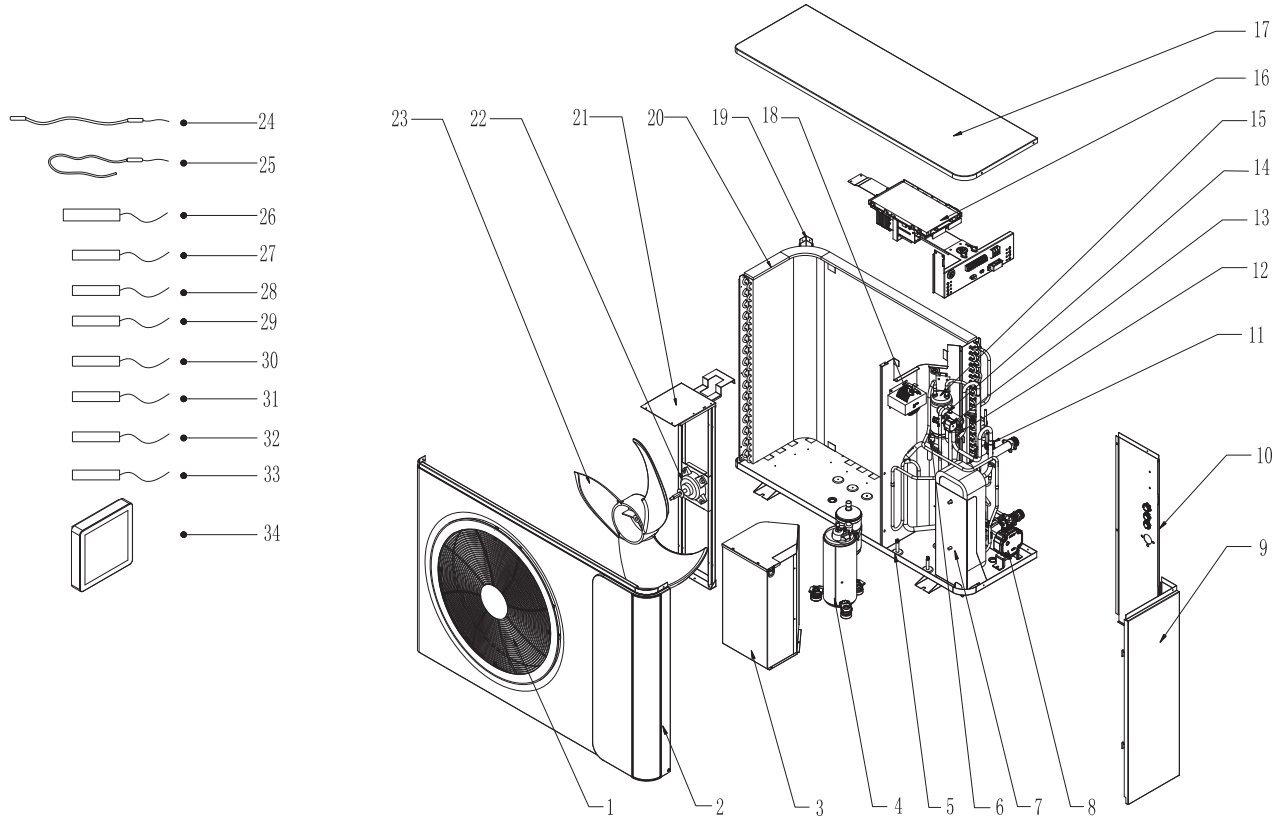

NO	Name	NO	Name
1	Fan Grill	18	Transducer
2	Front Panel	19	Back Column
3	Compressor Houseing	20	Evaporator
4	Compressor	21	Fan Motor Bracket
5	Bottom Plate	22	Fan Motor
6	High Pressure Switch	23	Fan Blade
7	Plate Heat Exchanger	24	Bottom Plate Heater
8	Water Pump	25	Comprssor Crankcase Heater
9	Service Panel	26	Compressor Discharge Temp. Sensor
10	Back Panel	27	Compressor Suction Temp. Sensor
11	Flow Switch	28	Outdoor Coil Temp. Sensor
12	Low Pressure Sensor	29	Ambient Temp. Sensor
13	4-way Valve Coil	30	Water Inlet Temp. Sensor
14	4-way Valve	31	Water Outlet Temp. Sensor
15	Accumulator	32	DHW Temp. Sensor Tw
16	Control PCB	33	Indoor Coil Temp. Sensor
17	Top Panel	34	Operation Panel

5. Attached drawing

5.3 Wiring Diagram

Monoblock — FSH HP 06V1FXC / FSH HP 09V1FXC / FSH HP 12V1FXC

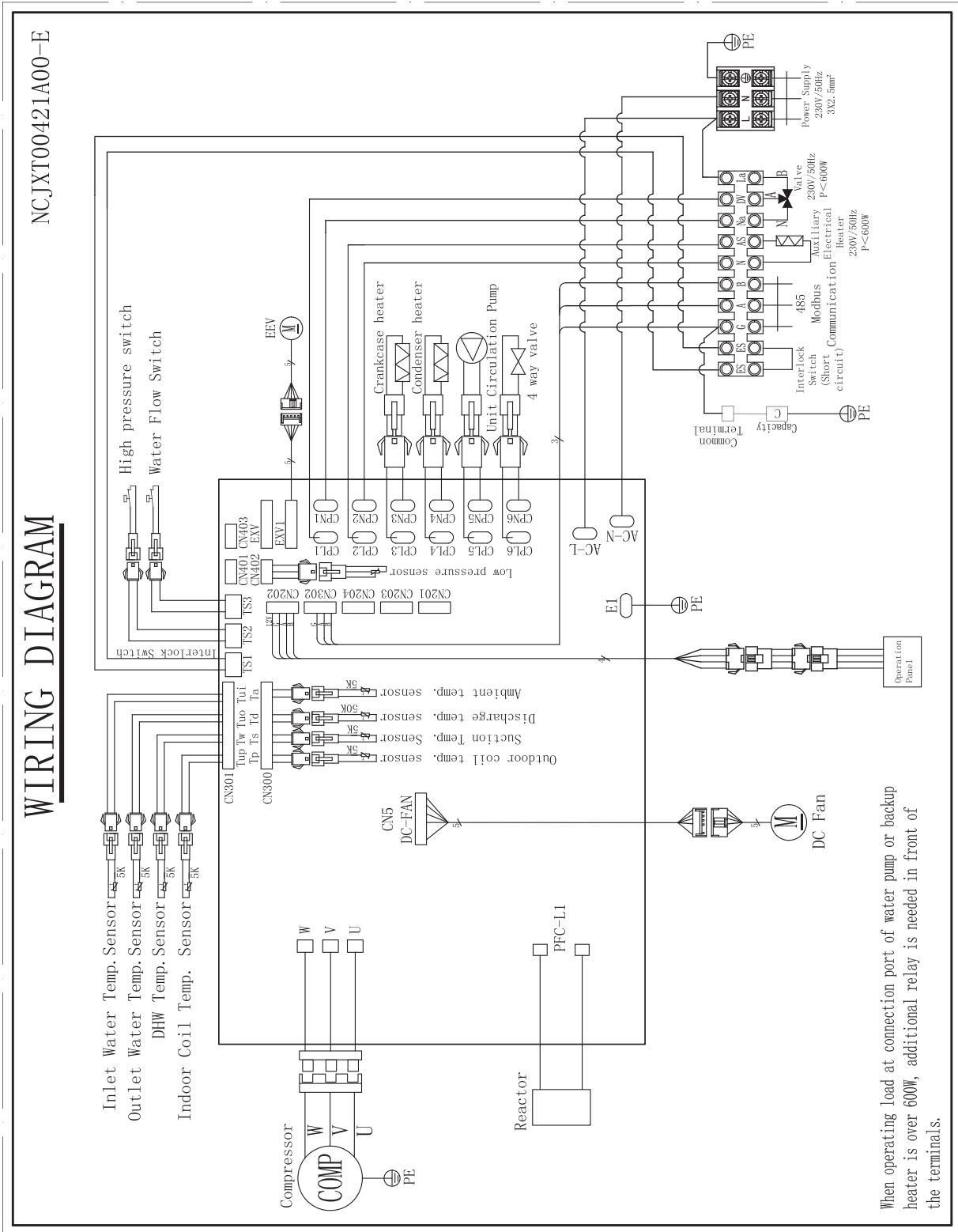

TAKE CARE!

This diagram is subject to change with improvement of the unit. Always refer to the diagram supplied with the product.

Thank you for choosing our quality product.
Please read this manual carefully before use and
follow the instructions to operate the unit in order
to prevent damages on the device or injuries to staff.

Specifications are subject to change with product
improvements without prior notice. Please refer to the
specification sticker on the unit for upgraded specifications.